

BZX/BZS - 4500 / 6500

4.5 & 6.5kW thyristor technology battery charger

GENERAL FEATURES:

- Designed for industrial environments
- High input-output isolation
- Adjustable output voltage
- Full functionality without batteries
- Optional 4.3' Colour Touch Screen with built-in WEB server
- Local monitoring and setting by the screen
- Remote monitoring with 8 alarm relays
- Optional remote monitoring and setting via Ethernet
- Optional selectable ground shunt monitoring*



Input voltage	Output current	24Vdc out	48Vdc out	72Vdc out	110/125Vdc out
230Vac	35 A	BZS-4500-5401 (*)	BZS-4500-5403 (*)	BZS-4500-5405 (*)	BZS-4500-5407
	50 A	BZS-6500-5411 (*)	BZS-6500-5413 (*)	BZS-6500-5415 (*)	BZS-6500-5417
3 x 400Vac	35 A	BZX-4500-5421 (*)	BZX-4500-5423 (*)	BZX-4500-5425 (*)	BZX-4500-5427
	50 A	BZX-6500-5431 (*)	BZX-6500-5433 (*)	BZX-6500-5435 (*)	BZX-6500-5437

Note (*) Under request



INPUT	
AC input voltage	See table
AC input voltage (range)	± 15%
AC input frequency (range)	42.5 ... 69 Hz
Power factor	>0,8
Efficiency	>85% at full load
Inrush current	< 180A
OUTPUT	
Default output voltage	See table
Output voltage adjustment range	-20 ... +32 %
Maximum output current	See table
Static voltage regulation	< ±1 % typical
Line voltage regulation	< ±1 % typical
Dynamic voltage regulation	< 15 % (Δ 20% to 100% to 20% Load)
Response time / Stabilization time	< 100 ms
Ripple (BW: 20mHz)	< 1% with battery < 3% without battery
CHARGER	
Battery types	PB / Optional NiCd
Charging characteristic	CC/CV according to DIN41773
Temperature compensation	Optional
Maximum charging current	See table
Battery self-consumption	< 6,5W
Environmental requirements	RoHS according to directive 2011/65/EU and REACH
ENVIRONMENTAL	
Storage temperature	-40°C ... 85°C
Operating temperature range	-10°C ... 40°C
Cooling	Natural convection
Maximum Relative humidity	5 ... 95% with no condensation
Altitude	1000 m
MTBF	TBD
Audible noise (dB)	TBD
EMC	
Emission according to	EN61000-6-4:2019 (optional EN61000-6-5)
Immunity according to	EN61000-6-2:2019 (optional EN61000-6-5)
SAFETY	
Safety according to	EN62368-1A
Dielectric strength Input-Output	2000Vac, 50Hz, 1min.
Dielectric strength Input-Earth	4000Vac, 50Hz, 1min.
Dielectric strength Output-Earth	2000Vac, 50Hz, 1min.
MECHANICAL	
Dimensions (H x W x D)	2000 x 600 x 600 mm (Feet not included)
Approximate weight without batteries	~200 kg
Paint	RAL 7035 o 9002 – IP21



CONTROL

Display	16x2 LCD display or 4.3' Touch Screen
Local control	RS-232 MODBUS/ RS-485 MODBUS
Alarm contacts	6 relays with contacts NO: <ul style="list-style-type: none">• Grid Failure• Non urgent failure• Urgent Failure• Battery end of autonomy• Rest: Configurable
Alarms Dielectric Strength	500 Vrms AC for 1 minute
Alarms Maximum Supply Voltage	100VDC
Optional remote control	Monitored parameters: <ul style="list-style-type: none">• Input voltage• Input current• Output voltage• Output current• Battery voltage• Battery current• Battery temperature (optional)• Battery electrolyte level (optional)

PROTECTIONS

Against overloads and short-circuits	Current limiting
Battery over-temperature	With ACC-TESE-0001 accessory
Against Input over-current	MCB bipolar
Against Output over-current	Fuse
Against Battery over-current	Fuse at both poles



Part Number	Nominal Input voltage [Vac]	Maximum Input current [A] (*)	Nominal Output Voltage [V]	Default Maximum Charging current [A]	Maximum Output current [A]	Maximum Output Power [kW] (*)
BZS-4500-5401	230	2,57	24	35	35	0,97
BZS-4500-5403	230	5,15	48	35	35	1,93
BZS-4500-5405	230	7,72	72	35	35	2,90
BZS-4500-5407	230	13,40	125	35	35	5,03
BZS-6500-5411	230	3,68	24	50	50	1,38
BZS-6500-5413	230	7,35	48	50	50	2,76
BZS-6500-5415	230	11,03	72	50	50	4,14
BZS-6500-5417	230	19,15	125	50	50	7,19
BZX-4500-5421	3 x 400	2,57	24	35	35	0,97
BZX-4500-5423	3 x 400	5,15	48	35	35	1,93
BZX-4500-5425	3 x 400	7,72	72	35	35	2,90
BZX-4500-5427	3 x 400	13,40	125	35	35	5,03
BZX-6500-5431	3 x 400	3,68	24	50	50	1,38
BZX-6500-5433	3 x 400	7,35	48	50	50	2,76
BZX-6500-5435	3 x 400	11,03	72	50	50	4,14
BZX-6500-5437	3 x 400	19,15	125	50	50	7,19

Note (*) Maximum Input Current is calculated at maximum output power considering a power factor of 0.85

ACCESSORIES

ACCESSORIES	CODE
16x2 LCD Display(**)	ACC-DISP-0001
4.3" Touch Screen with built-in WEB server(**)	ACC-DISP-0002
NiCd battery electrolyte level alarm	*
Batteries Pb	*
Input current monitoring	ACC-CUSE-0003 (for BZX models) ACC-CUSE-0002 (for BZS models)
Anti-reverse output diode	ACC-DDAR-0001 (for 6500 models) ACC-DDAR-0002 (for 4500 models)
Input voltage 277V / 3x480V	*
Open brakers/fuses detection	ACC-APAX-0001 (for 6500 models) ACC-APAX-0002 (for 4500 models)
Relays module (NO, C or NC)	ACC-REMO-0002
Molded Case Circuit Breakers + auxiliary contact	*
Output voltage reduction by diodes	ACC-DIRE-0001
Battery temperature probe	ACC-TESE-0001
Output insulation monitoring device	ACC-VGAI-0001
Fixed tray for batteries	*
Sliding tray for batteries type bucket (For NiCd)	*
Other cabinet paint color	***

Note (*) Under request

Note (**) Select only one of them.

Note (***) During the purchase, indicate your preferred color.

BLOCK DIAGRAM

Monofásico

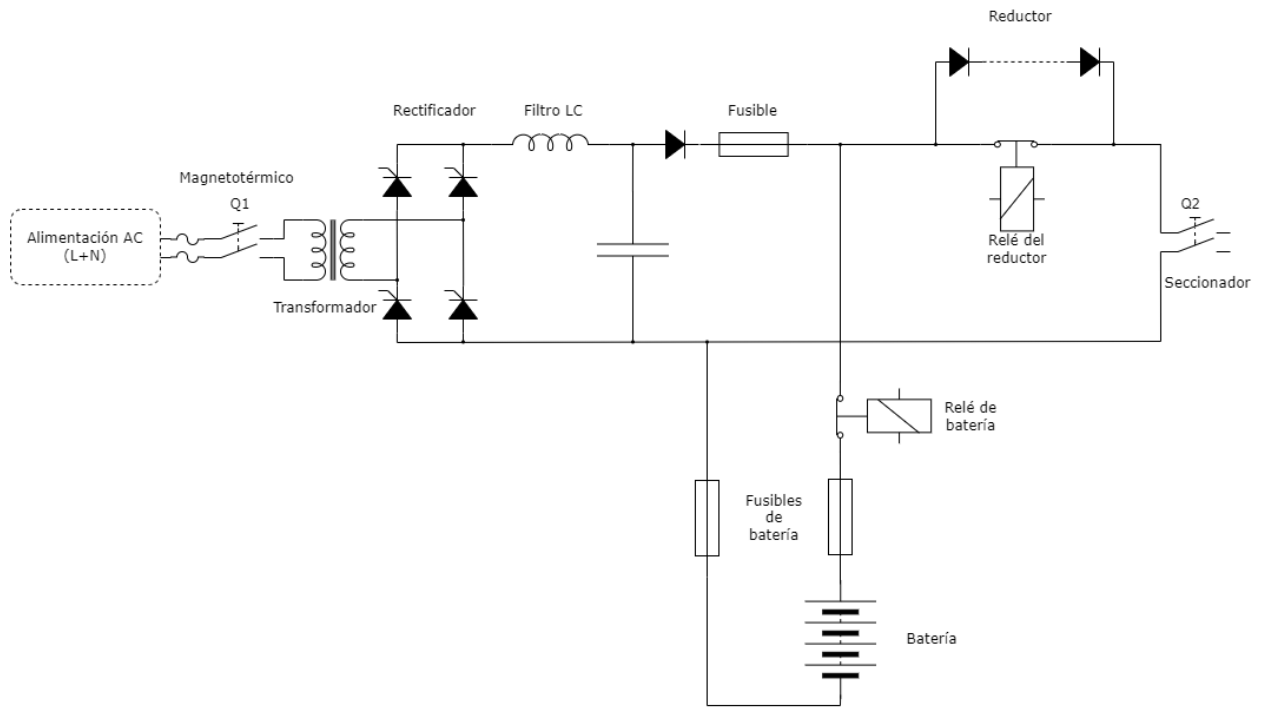

Trifásico

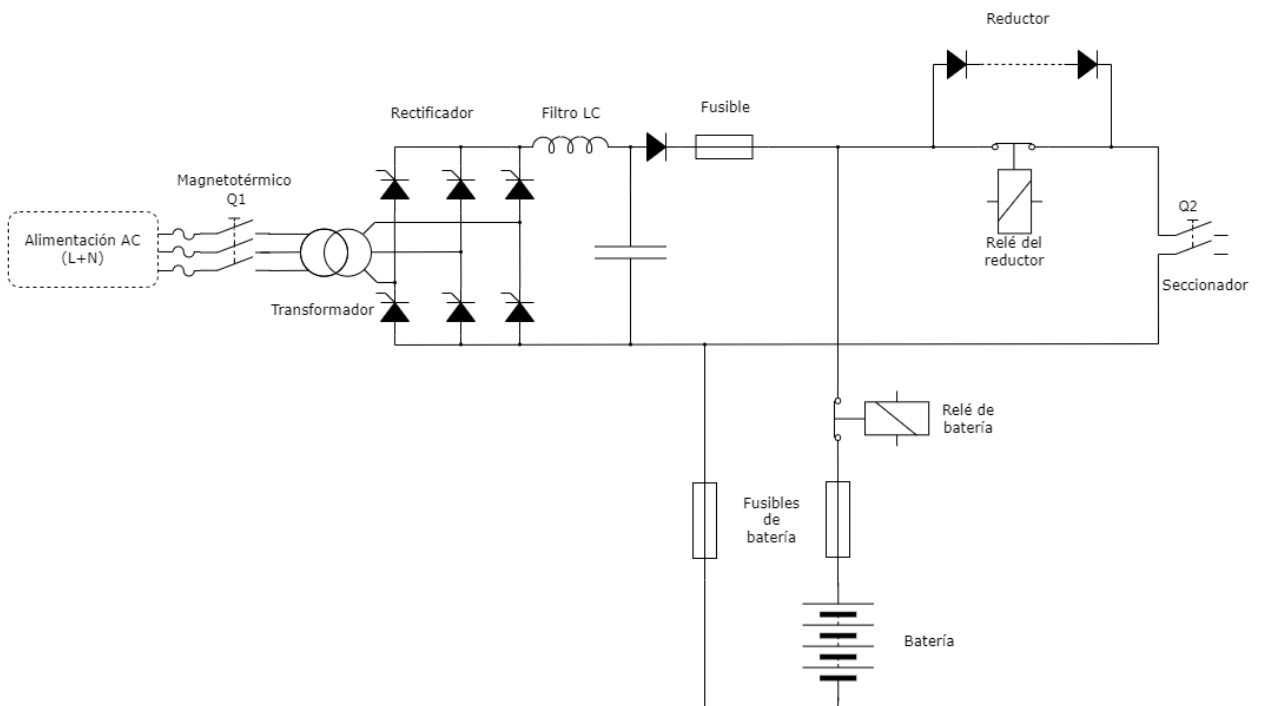



DESCRIPTION

Rectifier

BZS / BZX - 4500 / 6500 is a charger family based on a thyristor technology. The device is essentially formed by a transformer whose primary winding is connected to the electrical grid and secondary winding is connected to a thyristor controlled rectifier. The rectified voltage is filtered by an LC filter to obtain the desired DC output. The output current and voltage are controlled through the variation of the trigger angle.

This technology is considered the most reliable and lasting technology due to its simplicity and the robustness of its power elements.

The BZS / BZX - 4500 / 6500 is an uninterruptible power supply which allows:

- An uninterruptible supply between its specified limits.
- Protection from normal operations (start up, punctual overloads, etc.), as exceptional operations (short circuit, constant overload, etc.)
- A battery charge process which minimizes its charging time and maximizes the battery life by adjusting the voltage in floating and fast-charging conditions according to the ambient temperature and avoiding deep battery discharges.

In normal operation, the device supplies the constant consumption of the installation and keeps the battery charged at its nominal floating voltage. In case of a grid failure, the consumption of the installations will be obtained directly from the battery.

The battery charge is made by the CC-CV (Constant Current – Constant Voltage) curve. As it is explained before, when the grid fails, the battery keeps the output voltage. Once the grid voltage is restored, the charger-rectifier comes back automatically to its initial state.

The device is able to supply the load and charge the battery at the same time, as long as the sum of the currents is equal or below the nominal. This process is automatic, and there is no need for a manual operation (local or remote) in any time.

The Charger-rectifier can operate with or without the battery as long as the electrical grid is present. A battery disconnection does not cause any interruption at the output. When there is no battery, the output voltage is regulated at the battery floating voltage.

Moreover, the Charger-rectifier can have a high-precision temperature sensor to adapt the battery charge according to its temperature.

Configuration

The basic configuration of the device is made by MODBUS or Ethernet (only available with ACC-DISP-0002) without the need of proprietary applications neither measurement instrumentation.

The basic configuration allows the modifications settings like floating voltage, voltage compensations with temperature, charging voltage, etc.



MECHANICAL DRAWINGS

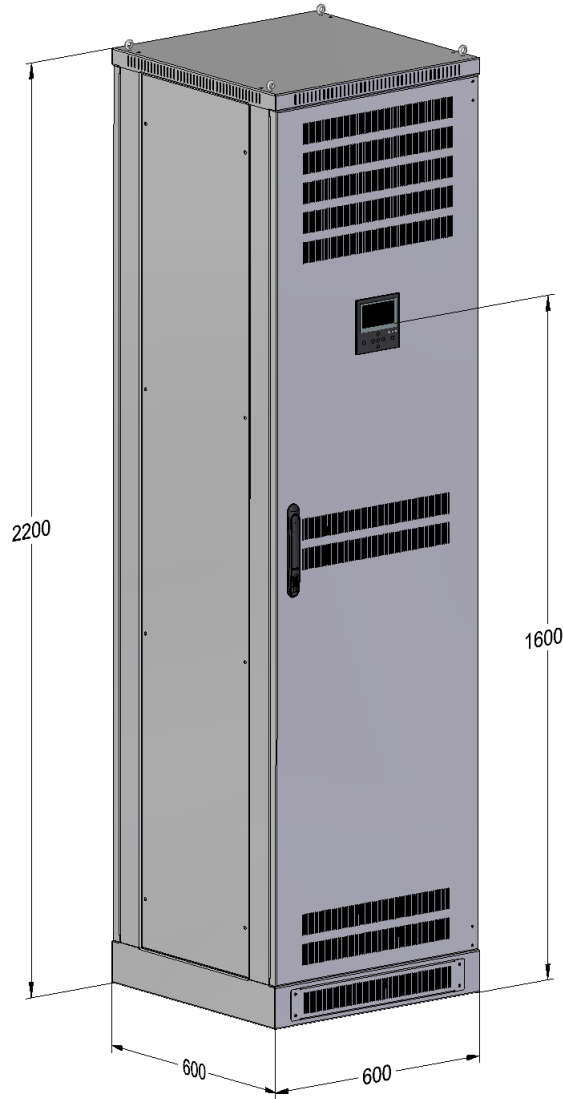

General dimensions (mm)