



Premium
Powering Your Challenge

FLEXSTORM SERIES



MAINTENANCE AND REPAIR GUIDE



INDEX

1. INTRODUCTION	3
2. COMPONENTS	4
3. MAINTENANCE	9
3.1 Equipment reviews.....	9
3.2 Screen map (TSS User)	9
3.3 Meaning of alarms	13
3.4 Replacement of power module (FDS).....	13
3.5 Replacement of control module	15
3.6 Replacement of communications module.....	16
3.7 Maintenance of batteries	16



1. Introduction

This quick maintenance guide contains the necessary information to carry out the correct maintenance of the FLEXSTORM SERIES system and in case of failure, how to reset the system safely. Please read this manual carefully before handling the FLEXSTORM SERIES system.

In no case does this quick system repair and maintenance guide replace the equipment's "User's Manual" or the "Safety Considerations" document. Please familiarise yourself with the information contained in both documents before operating the FLEXSTORM SERIES converter.

This manual must be kept inside the cabinet, in the drawer of the system door provided for this purpose. For further information on the equipment, please refer to the user manual. This document may not be edited or reproduced in whole or in part without the permission of Premium PSU

Visit our website www.premiumpsu.com for more information or contact technical support.

2. Components

Figure 1 - Distribution of components. Front view

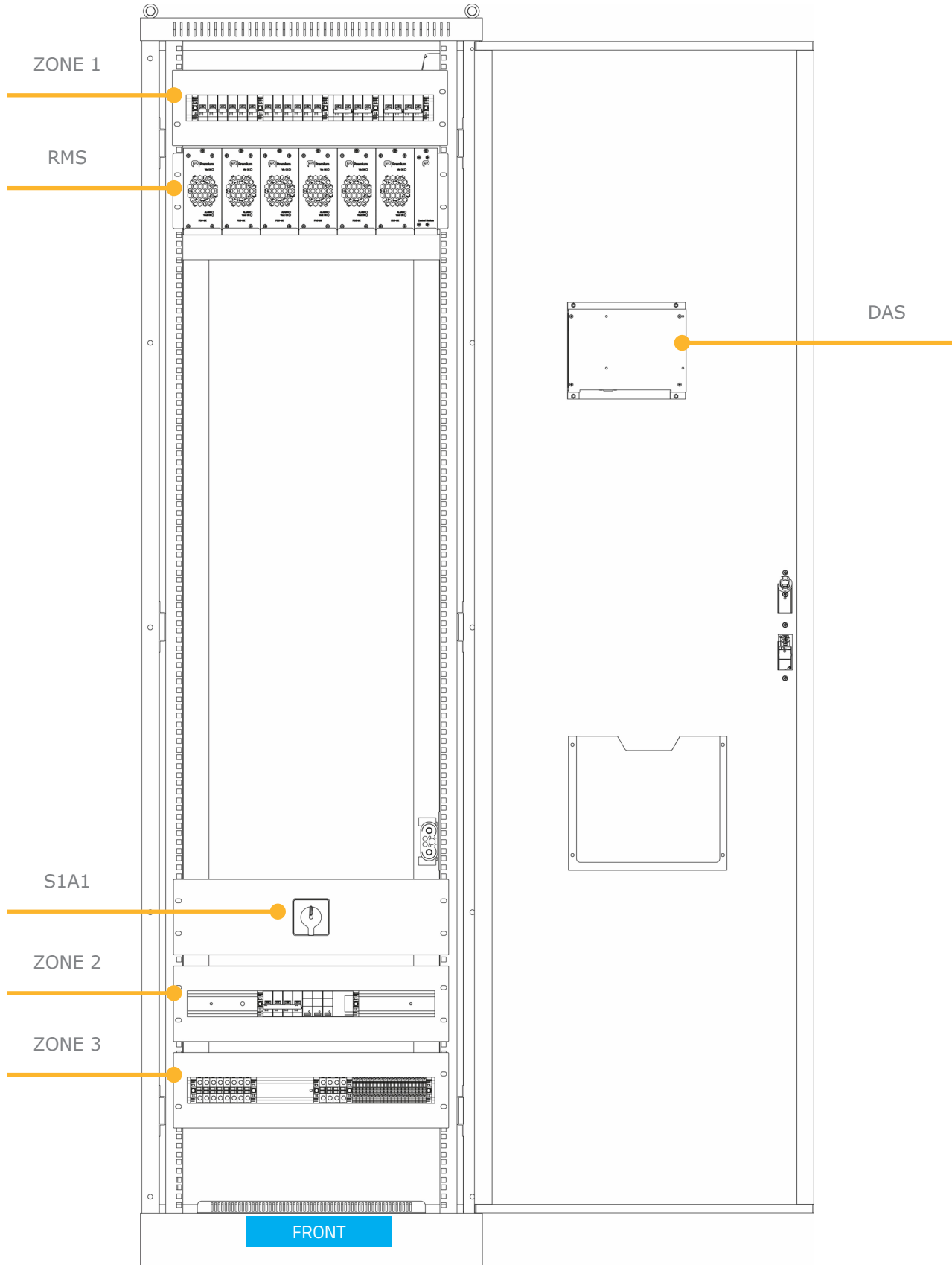
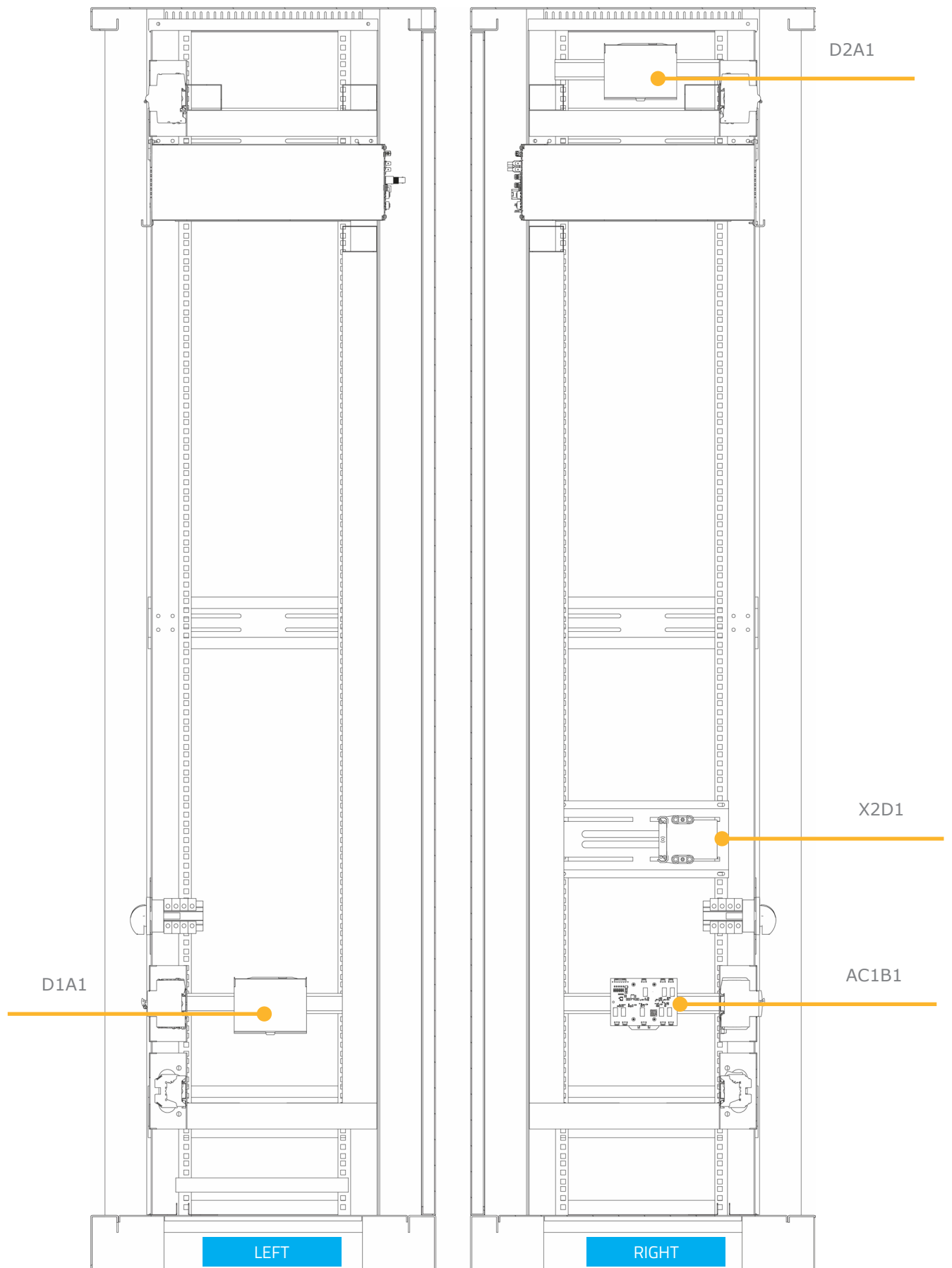



Figure 2 - Distribution of components. Left and right cut





COMPONENT	DESCRIPTION
RMS	Subrack 19" mechanical enclosure for up to 6 FDS and 1 LMS
DAS	Communications module with touch screen display
S1A1	3-position input supply voltage selector
AC1B1	ACC-REMO-0001: Alarm relay module
X2D1	Battery discharge safety connector
D1A1 and D2A2	Wiring distributor
Q1B1	Single-pole single input circuit breaker. Module 1
Q1B2	Single-pole single input circuit breaker. Module 2
Q1B3	Single-pole single input circuit breaker. Module 3
Q1B4	Single-pole single input circuit breaker. Module 4
Q1B5	Single-pole single input circuit breaker. Module 5
Q1B6	Single-pole single input circuit breaker. Module 6
Q2C1	Single-pole single-output circuit breaker. Module 1
Q2C2	Single-pole single-output circuit breaker. Module 2
Q2C3	Single-pole single-output circuit breaker. Module 3
Q2C4	Single-pole single-output circuit breaker. Module 4
Q2C5	Single-pole single-output circuit breaker. Module 5
Q2C6	Single-pole single-output circuit breaker. Module 6
K2A1	Auxiliary contact associated with the battery MCB
Q2D1	Double-pole battery circuit breaker. Positive
Q2D2	Double-pole battery circuit breaker. Negative
K2A2	Auxiliary contact associated with the general output circuit breaker of the system



COMPONENT	DESCRIPTION
Q2D3	Double-pole output circuit breaker. Positive
Q2D4	Double-pole output circuit breaker. Negative
X2C1	Relay contacts associated with Alarms
X1A1	Three-phase input voltage terminal for power supply input 1
X1A2	Three-phase input voltage terminal for power supply input 2
Q1A1	General 3P+N input circuit breaker
ST1A1	Surge arrester with interchangeable cartridges
X2B1	General battery terminal
X2B2	General battery terminal
F1A1	3-pole fuse holder 10.3 x 38 mm
F1B1, F1B2 and F1B3	Fuses for F1A1

3. Maintenance

In the event of a failure, the battery will remain connected, so the procedures for changing components must be followed.

Dangerous voltages are present inside the rectifier cabinet, even when the input voltage is switched off, as well as hot metal parts.

Direct contact can cause electrocutions and burns. The equipment may only be handled by authorised technical personnel.

3.1 Equipment reviews

Before starting, check that the connections on the earthing plate are connected correctly.

Before handling the equipment for any action, check that the door display does not indicate any alarm. If any of these are noted, please refer to the user's manual of the equipment.

In correct operation, each individual power module must show the "Vin OK" and "Vout OK" LEDs lit and green, the "ALARM" LED must be off.

Check that the connections are correctly made.

3.2 Screen map (TSS User)

3.2.1 Start-up

When the system is started, the display of the communication module (DAS) shows the screen of Figure 6.



Figure 6 - Equipment start-up

3.2.2 Main Screen

The main screen can be accessed after the unit has started or while the unit is booting by touching the screen. On this screen you can see the input parameters, output parameters, battery status and system configuration. The initial screen is shown below.

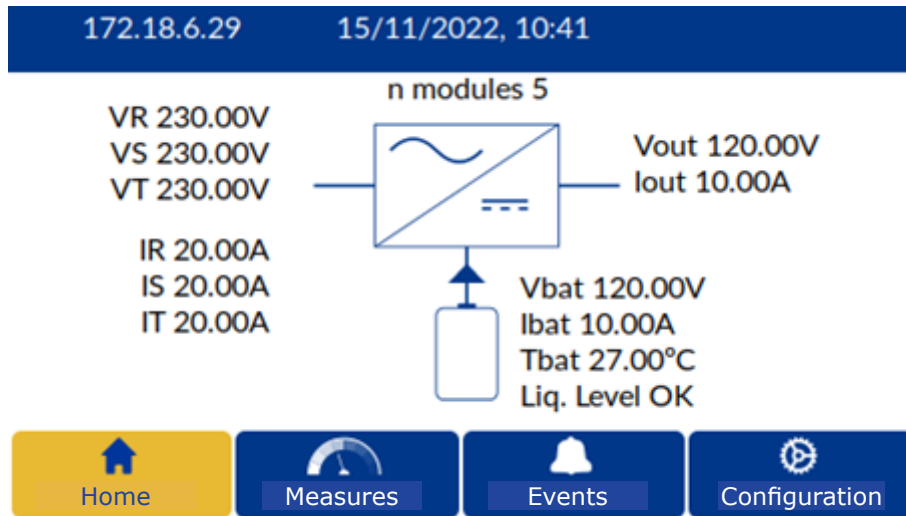

Figure 7 – Initial Screen

Information related to the status of the output circuit breakers / battery and the status of the input surge protector, in case of failure, shall be displayed as shown in the following Figure 8.

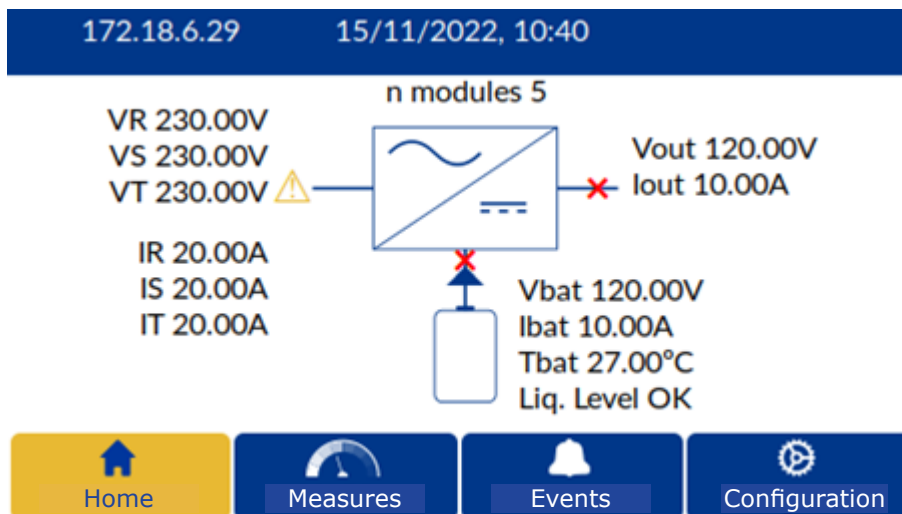

Figure 8 - Initial screen with alarms

As can be seen in the Figure 7, the display is divided into four sections, the initial screen, already described, the Measurements, Events and Configuration sections.

3.2.3 Measurements

By tapping on the measurements section, the image of Figure 9 is displayed. In this screen you can access the measurements of each power module individually and the measurements of the complete system by returning to the screen shown in figure Figure 7.

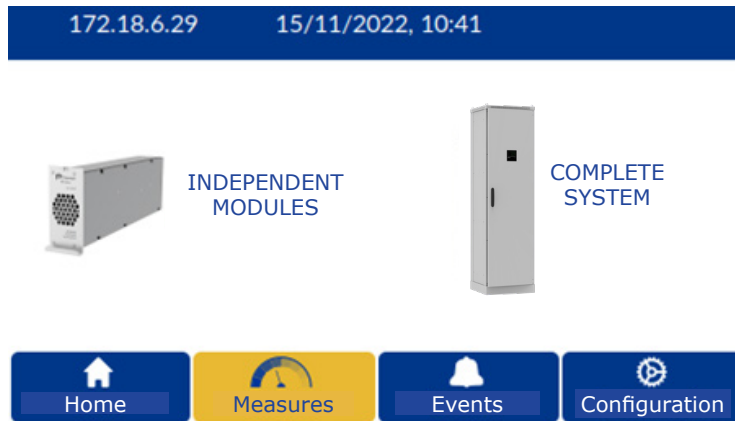

Figure 9 – Measurement screen

In the individual modules section (Figure 10), you can access the individual information of each module, and can navigate between the different modules detected by the control module (LMS). To change the module to be displayed, use the blue arrows on the screen or by the navigation panel itself, touching on the grid and directly selecting the desired module (Figure 11).

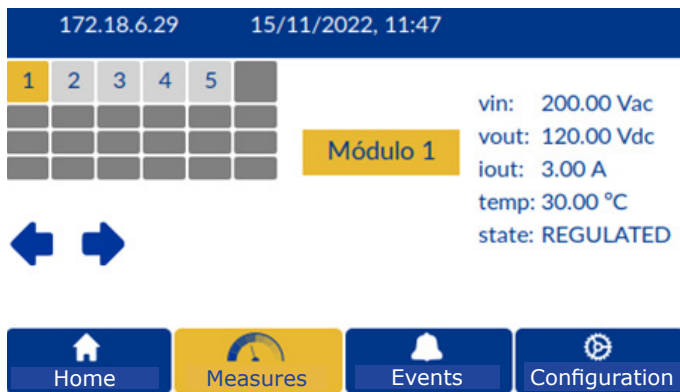

Figure 10 – Measurements screen - Independent modules

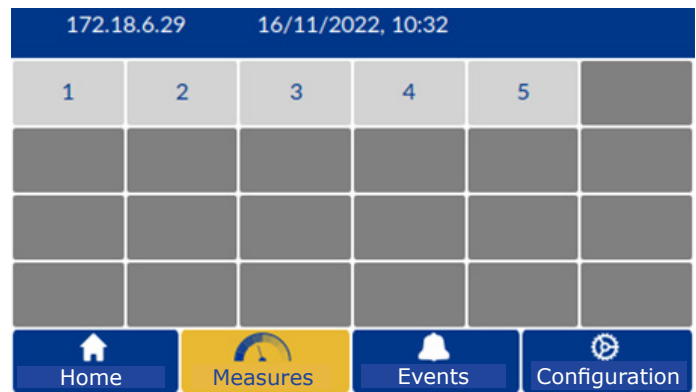

Figure 11 – Measurement screen - Stand-alone modules - Quick access

3.2.4 Events

Accessing the Events section, via the screen shown in Figure 7, displays the screen of Figure 12. It displays the event log with information about each event, such as the date, time and quick description of the event.

172.18.6.29		15/11/2022, 10:45	
N°	Date	Hour	Description
12	2022-11-15	08:57:03	Alarm "Abnormal low voltage in the battery" Active
11	2022-11-15	08:57:03	Event "device power up": POR 0.0
10	2022-11-14	11:48:56	Alarm "Abnormal low voltage in the battery" Active
9	2022-11-14	11:48:56	Event "device power up": POR 0.0

Bottom navigation bar: Home, Measures, Events, Configuration

Figure 12 - Event screen

3.2.5 Configuration

The system configuration can be accessed from any screen (Figure 13). Here you can select which type of configuration you want to access, the system configuration, the general configuration of the equipment or the actions that can be carried out locally.

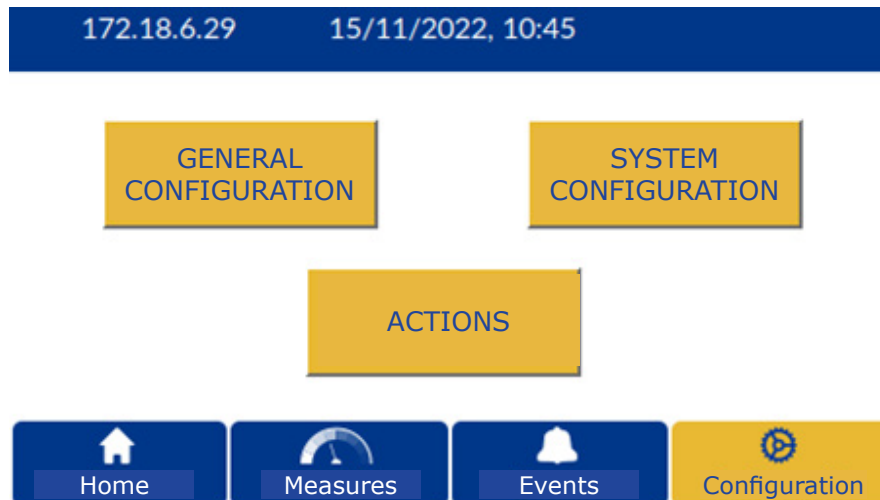

Figure 13 - Configuration screen

Refer to the user manual for more detailed information on the configuration of the equipment.

3.3 Meaning of alarms

Alarms are 100% configurable. These will depend on the individual configuration of the equipment. For more information on alarm configuration, please refer to the "User Manual".

3.4 Replacement of power module (FDS)

3.4.1 Complete module

For a complete replacement of a power module (FDS) due to a general failure, the procedure shall be as follows:

1. Disconnect the output circuit breaker corresponding to the module to be removed (Q2C_)
2. Disconnect the input circuit breaker corresponding to the module to be removed (Q1B_)
3. Wait for the "Vout OK" LED on the module to go out
4. Unscrew the upper screw of the module to be replaced
5. Pull the module by its handle until it is completely removed

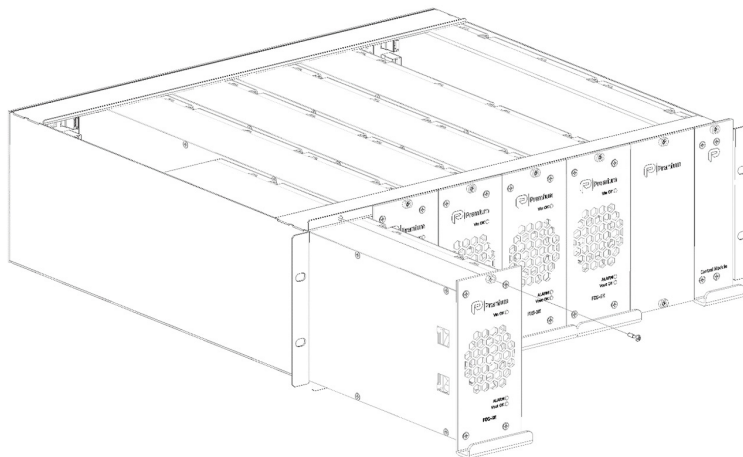

Figure 14 - FDS replacement

To mount the new FDS power module, the process must be repeated in reverse order:

1. Insert the new module until it connects to the rear backplane of the RMS subrack.
2. Screw the module to the subrack.
3. Connect the output circuit breaker corresponding to the module (Q2C_).
4. Connect the input circuit breaker corresponding to the module (Q1B_).
5. If the module has been installed correctly, the "Vin OK" and "Vout OK" LEDs should be on and green, the "ALARM" LED should remain off.

3.4.2 Fan

To replace the fan of a power module (FDS) due to a failure, the procedure shall be as follows:

1. Disconnect the output circuit breaker corresponding to the fan module to be removed (Q2C_)
2. Disconnect the input circuit breaker corresponding to the fan module to be removed (Q1B_)
3. Wait for the "Vout OK" LED on the module to go out
4. Unscrew the upper screw of the module
5. Pull the module by its handle until it is completely removed
6. Remove the front cover of the module by unscrewing the 4 screws indicated
7. Disconnect the fan and pull it out of the PCB and the cover tabs

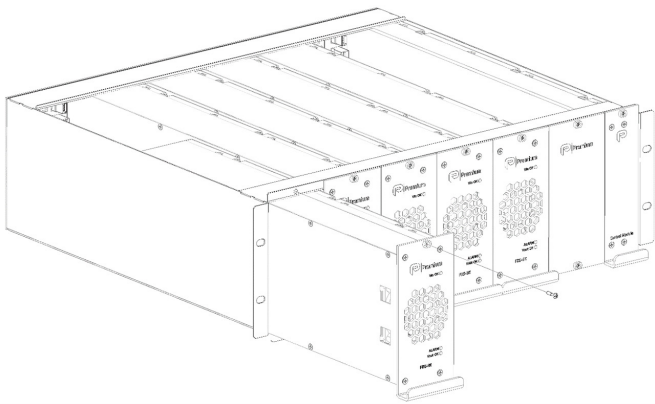

Figure 15 – Replacement fan > Step 1

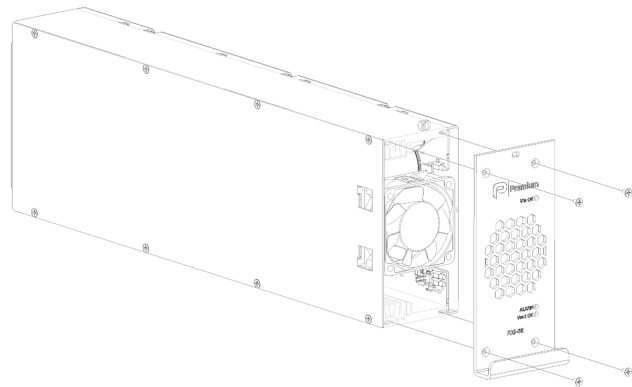

Figure 16 – Replacement fan > Step 2

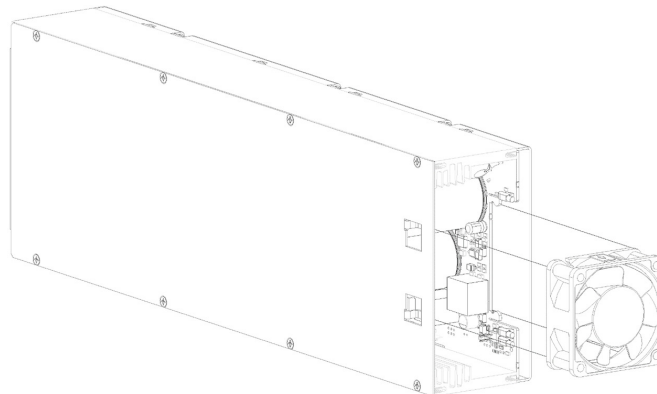

Figure 17 – Replacement fan > Step 3

To mount the new fan, the process must be repeated in reverse order.

1. Connect the new fan to the module and insert it until it fits the PCB and is securely fastened by the tabs on the side of the module
2. Check that the fan is in the correct position. The fan must be installed in position so that it blows air into the module
3. Screw on the front cover of the module with the four screws
4. Insert the new module until it connects to the rear backplane of the RMS subrack
5. Screw the module to the RMS subrack
6. Connect the output circuit breaker corresponding to the module (Q2C_)
7. Connect the input circuit breaker corresponding to the module (Q1B_)

3.5 Replacement of control module

For a complete replacement of a control module due to a general failure, the procedure shall be as follows:

1. Unscrew the upper screw of the module to be replaced
2. Pull the module by its handle until it is completely removed

To mount the new control module, the process must be repeated in reverse order.

1. Disconnect any connections to the communications module (RJ45, Ethernet, etc.)
2. Remove the fastening nuts located on the door of the system enclosure
3. Remove the communications module by unplugging it from the cabinet turrets and the panel

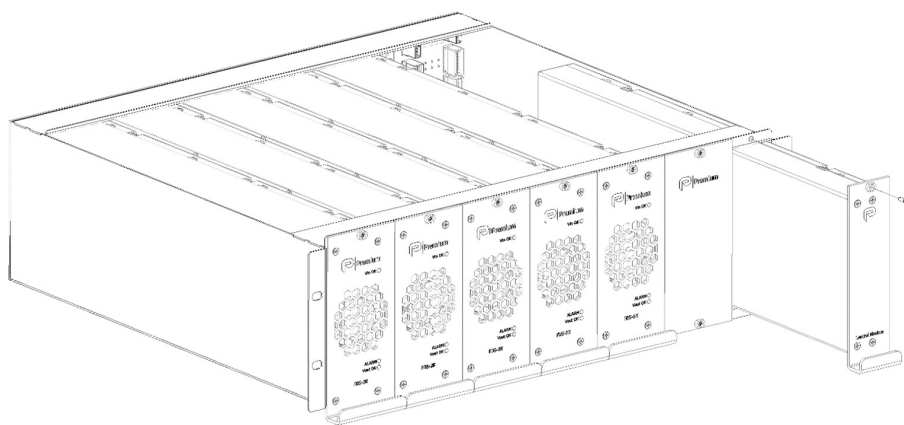

Figure 18 - Replacement of control module (LMS)

3.6 Replacement of communications module

To replace the communications module due to a failure, the procedure shall be as follows:

1. Disconnect any connections to the communications module (RJ45, Ethernet, etc.)
2. Remove the fastening nuts located on the door of the system enclosure
3. Remove the communications module by unplugging it from the cabinet turrets and the panel
4. Remove the 4 nuts and washers shown in the picture
5. Remove the communications module

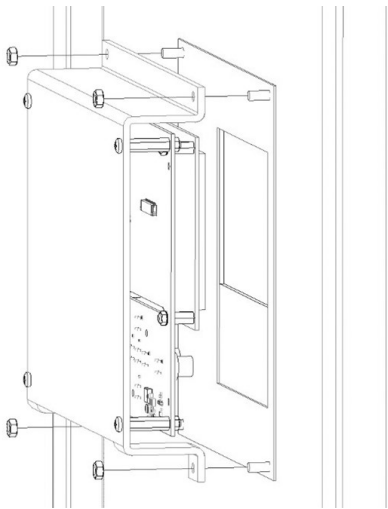

Figure 19 - DAS replacement > Step 1

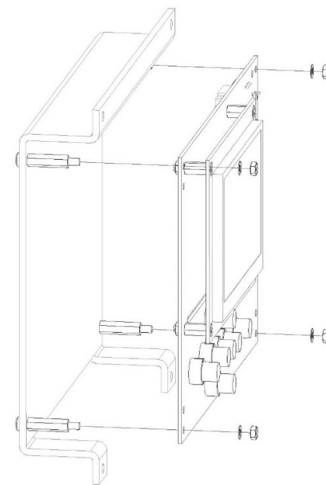

Figure 20 - DAS Replacement > Step 2

To install the new communications module you must repeat the process in reverse:

1. Place the new module and fit it between the 4 turrets located on the cabinet door of the FLEXSTORM SERIES system
2. Secure the module with the 4 washers and 4 nuts removed earlier
3. Mount the communications module in the cabinet by fitting it between the 4 turrets and the panel
4. Fix it to the cabinet with 4 nuts removed earlier
5. Connect up to the control module using the RJ45 cable provided
6. Once the system has been started, the display should show the main screen without communication failures with the control module. In case of any further problems, please contact the PREMIUM PSU Technical Support Service.

3.7 Maintenance of the Batteries

Batteries should be replaced at the end of their service life.

The lifetime of batteries is highly dependent on the ambient temperature and other factors such as the number of charges and discharges and the depth of these discharges.

In the safety instruction manual there is a specific chapter on batteries. Consult in case of tampering.



Premium

Powering Your Challenge

C/ Dolors Aleu, 19-21, Pl. 2^a
08908-L'Hospitalet de Llobregat
(Barcelona-Spain)

Send an email to hello@premiumpsu.com
or call us at +34 93 223 26 85

