

SDP-90

1AC DIN-Rail Power Supply

GENERAL FEATURES

- 85-276VAC widerange input
- 2U Width (36mm); 151g Weight
- Push-In connectors
- 90W at 120V: 40°C; at 230V: 60°C
- Efficiency 93.6%
- Constant current limited
- Power boost: 150% / 4.5s
- Audible noise suppression
- LPS; NEC class 2



DESCRIPTION

SDP -90 The high-end AC/DC module of the ultra-slim 2U "step-shape" housings with push-in button terminals delivers 90 Watt continuous output power and 150% peak power for 4.5s. The smart constant current limited power supplies are IEC and UL certified with output limitation per UL1310 NEC class 2. Din-Rail mounting is rated specifically in any orientation and if required supported by additional back-panel wings.

It's unique suppression of audible noise makes these flat panel power supplies ideal where distribution boards are situated in office and living areas.

SELECTION GUIDE

Part Number	Input Voltage Range	Input Voltage Range	Output Voltage nom.	Output Current Rated	Boost Current max ⁽¹⁾	Efficiency ⁽²⁾ typ.	rated Output Power (2)
	[VAC]	[VDC]	[VDC]	[mA]	[mA]	[%]	[W]
SDP-90-35024	85-277	88-370	24	3800	5700	93.6	91.2

Note1: Refer to „Boost Power Duty Cycle“.
 Note2: Refer to „Power Ratings“



BASIC CHARACTERISTICS (measured @ T _{AMB} = 25°C, 240VAC full load and after warm-up unless otherwise stated)					
Parameter	Condition		Min.	Typ.	Max.
Nominal Input Voltage	50/60Hz		100VAC		240VAC
Operating Range ⁽³⁾	47-63Hz		85VAC		276VAC
	DC input		88VDC		370VDC
Input Current	100-240VAC		1A		1.6A
	DC input: 110-240VDC		0.42A		1A
Inrush Current	cold start at 25°C	115VAC			12A
		230VAC			20A
No Load Power Consumption	115VAC			170mW	300mW
	230VAC			240mW	
Ecodesign Standby Mode Use (Available output power for stated input power)	PIN= 0.5W		140mW		
	PIN= 0.8W		350mW		
Input Frequency Range	AC Input		47Hz		63Hz
Nominal Output Voltage (factory set)				24VDC	
Output Voltage Adjustability ⁽⁴⁾	potentiometer	set point VOUT = 24VDC	24VDC		29VDC
Minimum Load			0%		
Power Factor				0.5	
Start-up time	120/230VAC			110ms	
Rise time	120/230VAC			20ms	
Hold-up time	120VAC			12ms	
	230VAC			50ms	
Internal Operating Frequency				65kHz	
Output Ripple and Noise ⁽⁵⁾	20MHz BW				1% of nom.Vout

Note3: The products were submitted to all safety files at AC-operation (100-240VAC ±10% tolerance)

Note4: Make sure that the maximum rated output power will not be exceeded when trimming up.

Note5: The test setup can have an impact on ripple noise values (placement of scope probe, capacitors, it's specifications, wires, distances, etc.)

Efficiency vs Output Power

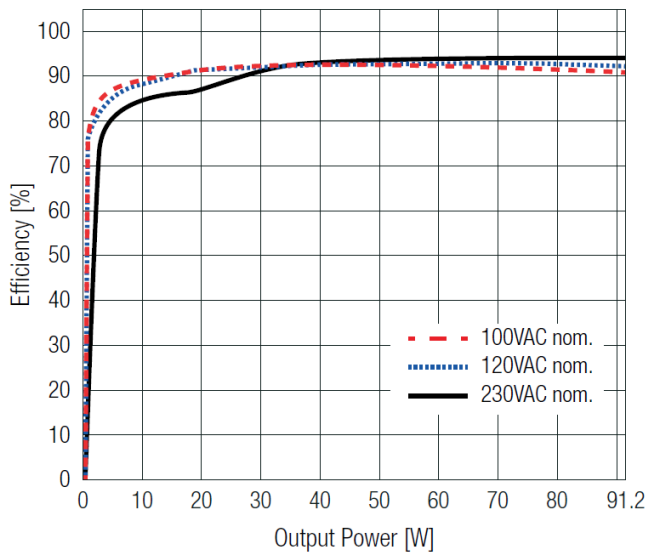

Dissipated Power vs. Output Power

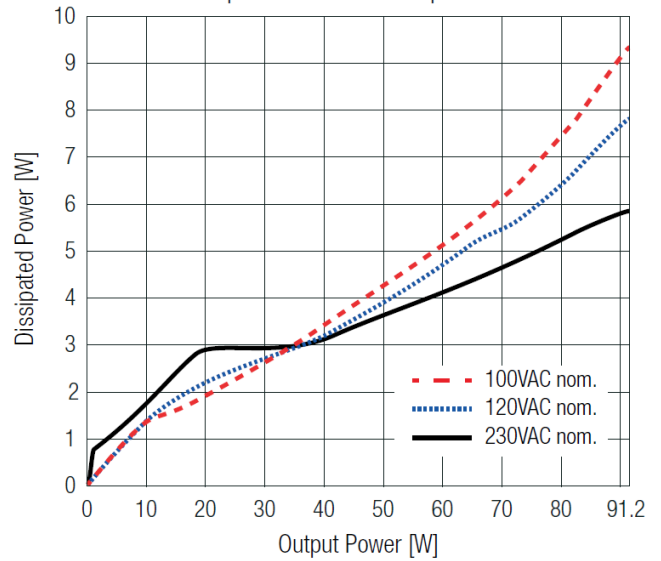

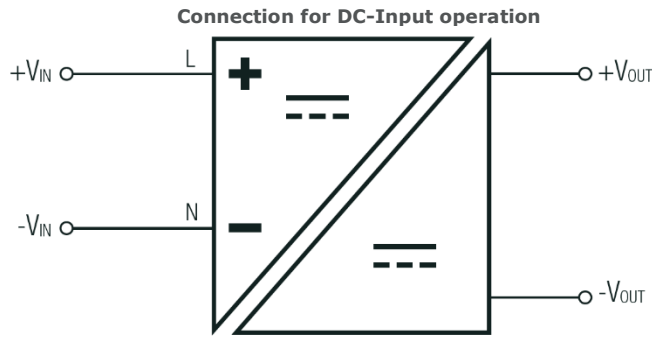

REGULATIONS (measured @ $T_{AMB}= 25^{\circ}C$, nom. V_{IN} , full load and after warm-up unless otherwise stated)		
Parameter	Condition	Value
Output Accuracy		$\pm 1.0\%$ max.
Line Regulation	low line to high line, full load	0.1% max.
Load Regulation ⁽⁶⁾	10% to 100% load	0.3% max.
Transient Response	25% load step change	1.5% max.
	recovery time	1.5ms max.

Note6: Operation below 10% load will not harm the converter, but specifications may not be me

PROTECTIONS (measured @ $T_{AMB}= 25^{\circ}C$, nom. V_{IN} , full load and after warm-up unless otherwise stated)			
Parameter	Type	Value	
Internal Input Fuse		T3.15A, slow blow type	
Limited Power Source (LPS)		yes	
Short Circuit Protection (SCP)	below 100m Ω	hiccup mode; auto recovery	
Over Current Protection (OCP)	≤ 5 sec	I limited to $U_{OUT} > 11VDC$; $< 10VDC$: hiccup	
	> 5 sec	$P < 150\%$: boost power; exceeding: hiccup	
Over Voltage Protection (OVP)		36VDC, hiccup mode	
Over Voltage Category (OVC)	according to 62368-1	OVC II (5000m)	
DC ON LED	LED green	output voltage present	
	LED off	abnormal mode, no operation or failure	
Class of Equipment		Class II	
Isolation Voltage	I/P to O/P	1 minute	3kVAC/4kVDC
Insulation Grade	I/P to O/P		reinforced

U/I Characteristic

Continuous use valid under input side up orientation and 120-240Vac input at T_{AMB} up to $40^{\circ}C$ max. For operation under different conditions, please contact Premium PSU Support.

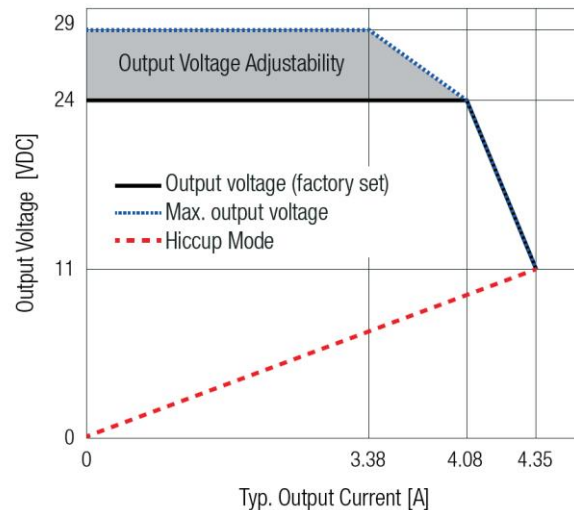



ENVIRONMENTAL (measured @ T _{AMB} = 25°C, nom. V _{IN} , full load and after warm-up unless otherwise stated)			
Parameter	Condition		Value
Operating Ambient Temperature Range	@ natural convection (0.1m/s); refer to „Power Ratings“		-40°C to +70°C
Maximum Case Temperature			+97°C
Operating Altitude ⁽⁷⁾	according to 62368-1; refer to „Altitude Derating (10)“		5000m (OVC II)
Operating Humidity			95% RH max.
Pollution Degree			PD2
IP Rating			IP20
Shock	according to IEC 60068-2-27 Fa non-operating		15G/11ms, 3 times (positive/negative) in all axis
Vibration	according to IEC 60068-2-6 Fc non-operating		5 - 8.4Hz @ 3.5mm deflection, 8.4 -150Hz @ 2G, 10 cycles /axis (min-max-min); 1 octave/min
MTBF	according to EN/IEC 61709 (SN29500)	T _{AMB} = +40°C	1800 x 10 ³ hours
Design Lifetime	full load, Input side up	T _{AMB} = +25°C	270 x 10 ³ hours
		T _{AMB} = +40°C	96 x 10 ³ hours
	full load, Input side down	T _{AMB} = +25°C	140 x 10 ³ hours
		T _{AMB} = +40°C	50 x 10 ³ hours

Note7: Recognized by safety agency for safe operation up to 5000m. High altitude operation may impact the performance and lifetime

Power Ratings for vertical module orientation ⁽⁸⁾

(@ Chamber and natural convection 0.1m/s)

Input side up: maximum lifetime
Input side down: reduced lifetime

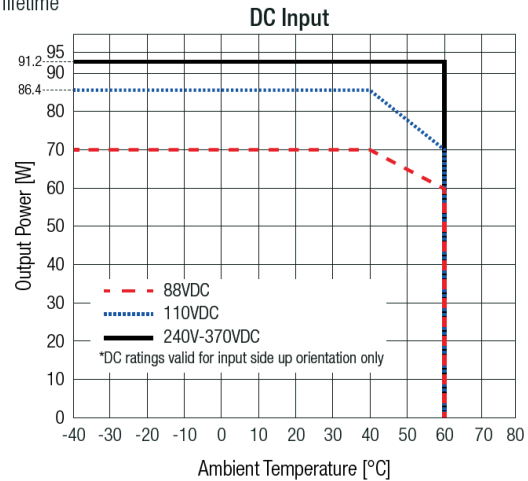
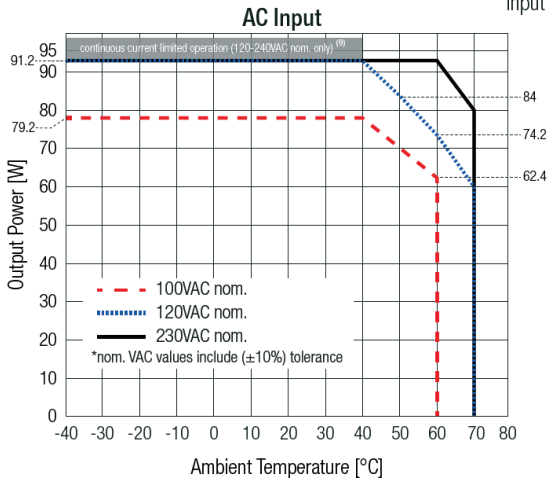

Note8: For horizontally oriented modules a reduced output to 85% of the indicated rating is recommended.

Note9: Permanent operation with quasi-constant current limited output is only intended up to 40°C and with nominal input of 120-240VAC, input side up oriented. With 100VAC nom. input a max. duration of 60s with 20% duty cycle is recommended. Otherwise contact Premium PSU Tech Support

Altitude Derating ⁽¹⁰⁾
(for continuous operation)

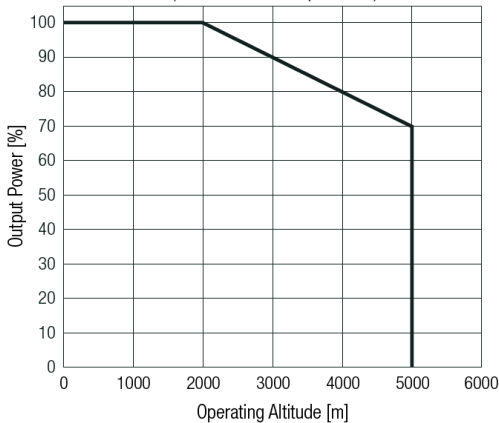

Note10: The altitude derating has no effect on the boost power, which is always permitted up to an ambient temperature of +60 °C.

BOOST POWER DUTY CYCLE

The boost power, is always permitted up to an ambient temperature of +60°C. Prated is determined from the above derating graphs, and the 150% boost power must be calculated based on this value

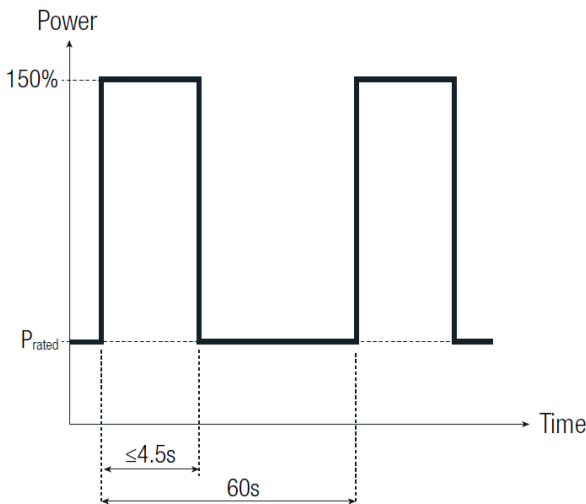

Practical Example:

P_{rated} = refer to „Power Ratings“ [W]
 P_{Boost} = Boost power (150% of P_{rated}) [W]

Take the SDP-90 at 120VAC input voltage and full load at $T_{AMB} = 50^{\circ}C$, with natural convection and input side up orientation:

$P_{rated} = 84W$
 $P_{Boost} = 126W$

SAFETY & CERTIFICATIONS SAFETY & CERTIFICATIONS

Certificate Type (Safety)	Report Number	Standard
Audio/Video, information and communication technology equipment - Part1: Safety requirements 3rd Edition		UL62368-1:2021 3rd Edition
		CAN/CSA-C22.2 No. 62368-1-19 3rd Edition
Class 2 Power Units		UL1310 (NEC Class 2)
Power Supplies With Extra-Low-Voltage Class 2 Outputs		CAN/CSA-C22.2 No. 223 3rd Edition
Audio/Video, information and communication technology equipment - Part1: Safety requirements 3rd Edition		IEC62368-1:2018 3rd Edition
		EN IEC 62368-1:2020+A11:2020

EMC Compliance	Condition	Standard / Criterion
Electromagnetic compatibility (EMC) - Part 6-2: Generic standards - Immunity standard for industrial environments		EN IEC 61000-6-2:2019
Electromagnetic compatibility (EMC) - Part 6-3: Generic standards - Emission standard for equipment in residential environments		EN IEC 61000-6-3:2021, Class B
ESD Electrostatic discharge immunity test	Air: $\pm 2, 4, 8kV$ Contact: $\pm 2, 4, 6kV$	IEC61000-4-2:2008, Criteria A EN61000-4-2:2009, Criteria A
Radiated, radio-frequency, electromagnetic field immunity test	10V/m (80-1000MHz)	IEC/EN61000-4-3:2006 + A2:2010, Criteria A
Fast Transient and Burst Immunity	AC Power Port: $\pm 0.5, 1, 2, 4kV$	IEC/EN61000-4-4:2012, Criteria A
	DC Output Port: $\pm 0.5, 1, 2kV$	
Surge Immunity	AC Port: L-N: 0.5, 1kV L-PE: $\pm 0.5, 1, 2kV$	IEC/EN61000-4-5:2014 + A1:2017, Criteria A
	DC Port: Vout: $\pm 0.5, 1kV$ Vout-PE: $\pm 0.5, 1kV$	
Immunity to conducted disturbances, induced by radio-frequency fields	10Vrms (0.15-80MHz)	IEC61000-4-6:2013, Criteria A EN61000-4-6:2014, Criteria A
Voltage Dips	100%: 0.5, 1, 5P 70%: 0.5, 1, 5, 10P 30/40%: 5, 10, 25P	IEC/EN61000-4-11:2004+A1:2017, Criteria B
Voltage Interruptions	100%: 250P	IEC/EN61000-4-11:2004+A1:2017, Criteria C
Limits of Harmonic Current Emissions		EN IEC 61000-3-2:2019
Limits of Voltage Fluctuations & Flicker		EN61000-3-3:2013+A1:2019



DIMENSION & PHYSICAL CHARACTERISTICS

Parameter	Type	Value
Materials	case/baseplate	plastic, (UL94 V-0)
	PCB	FR4, (UL94 V-0)
Dimension (LxWxD)		94.1 x 36 x 58.8mm 3.7 x 1.4 x 2.3 inch
Weight		151g typ. 0.33 lbs

Dimension Drawing (mm)

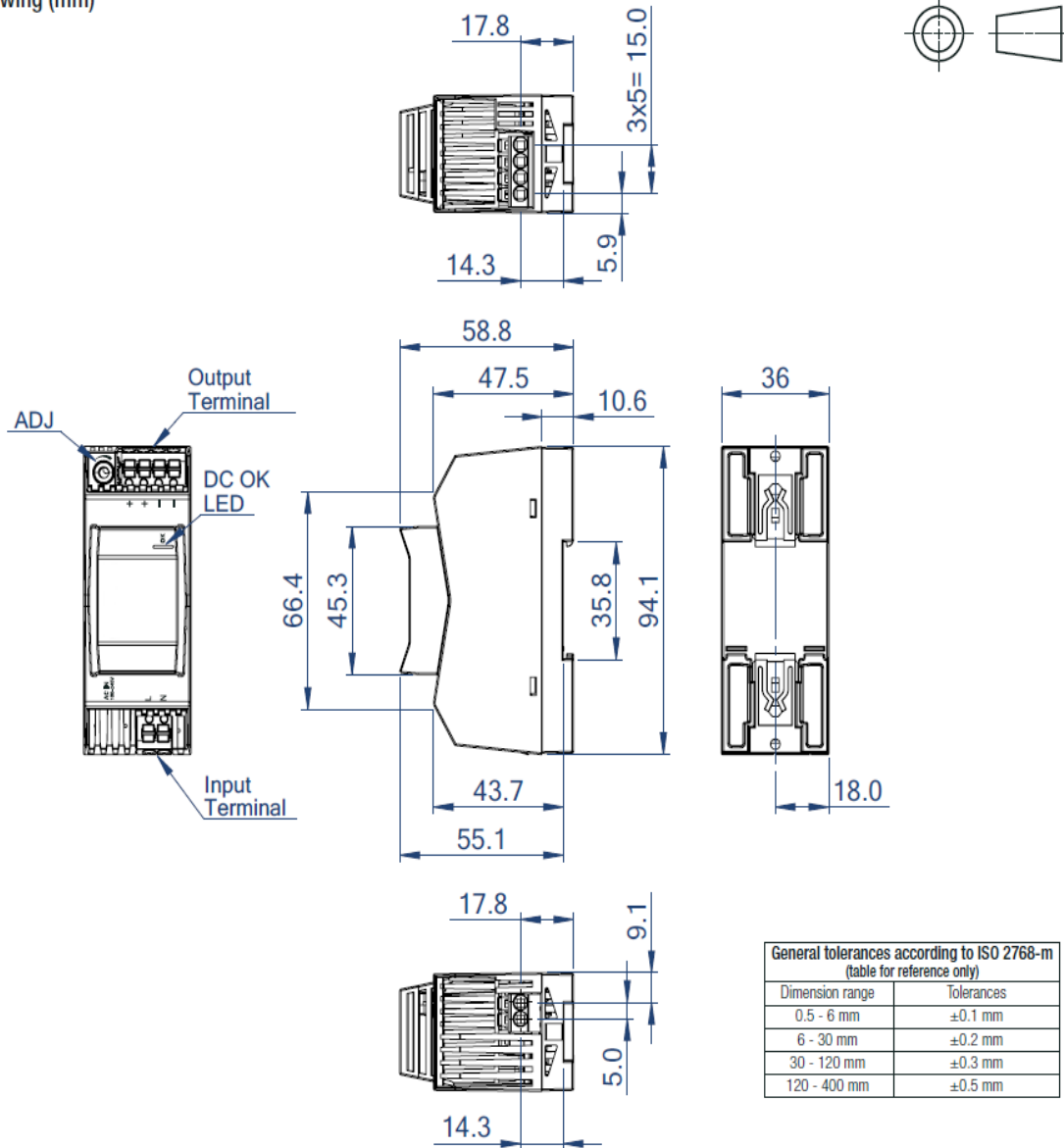

Dimension range	Tolerances
0.5 - 6 mm	±0.1 mm
6 - 30 mm	±0.2 mm
30 - 120 mm	±0.3 mm
120 - 400 mm	±0.5 mm

Connector Information

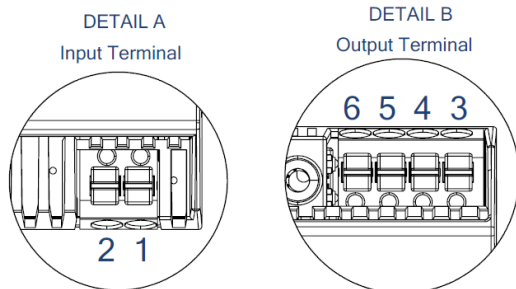

Push-In Terminal Information ⁽¹¹⁾

#	Function	AWG	mm ²
1	VAC _{IN} N	20-12	0.2-2.5
2	VAC _{IN} L	20-12	0.2-2.5
3,4	-Vout	20-12	0.2-2.5
5,6	+Vout	20-12	0.2-2.5

Wire stripping length: 10-11mm

Note11: Use flexible (stranded wire) or solid cables with above wire cross-section is recommended. Ferrules are recommended for flexible cables. Use copper conductors designed for an operating temperature of at least 90°C.

INSTALLATION & APPLICATION

Mounting Instruction

Mounting Rail: Standard TS35 DIN Rail in accordance with EN 60715.

Mounting

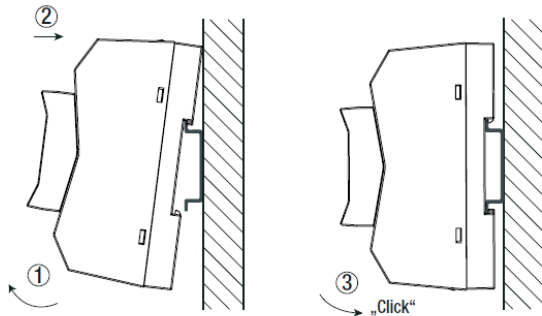

1. Place the device on the DIN rail with a slight upward tilt. Snap the device into the DIN rail.
2. Now tilt the device downwards until it reaches the lower part of the rail.
3. Press the lower part of the device firmly against the rail until the device locks into position on the DIN rail. "Click"
4. To make sure it is securely locked in place, give the device a gentle shake.

Release

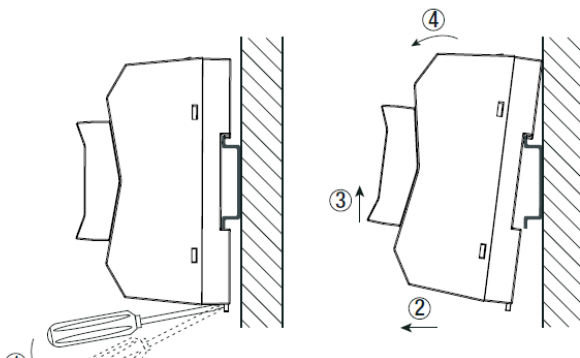

1. Pull the DIN rail latch by using a screwdriver OUT of the device and until it locks in position.
2. Tilt the bottom of the device OUT.
3. Pull the device away from the DIN rail by pushing it up.
4. Remove the power supply completely from the rail.

Mounting Instruction with extended mounting flanges

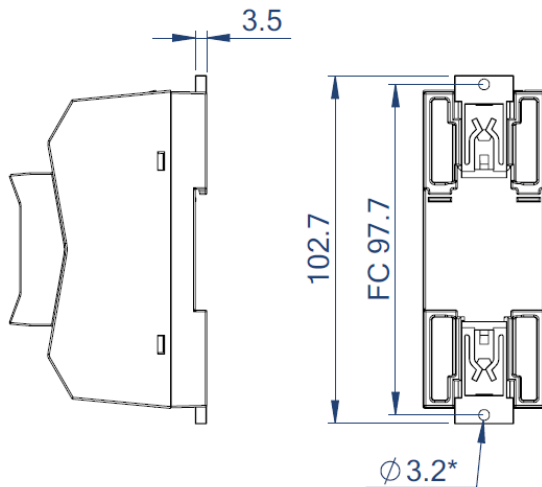

1. Press the mounting flanges out of the housing until they click into place.
2. Secure the device to the mounting surface using two M3 screws. Use cylinder head screws only. Countersunk screws are not permitted. Recommended tightening torque= 0.5Nm
3. To ensure that it is securely attached to the mounting surface, shake the device gently.

Installation Instructions

To guarantee sufficient convection cooling, keep a distance of 30mm above and below the device.

The device should be installed with the input side up (for maximum lifetime).

For horizontally oriented modules a reduced output to 85% of the indicated rating is recommended.

The modules can be placed directly next to each other.

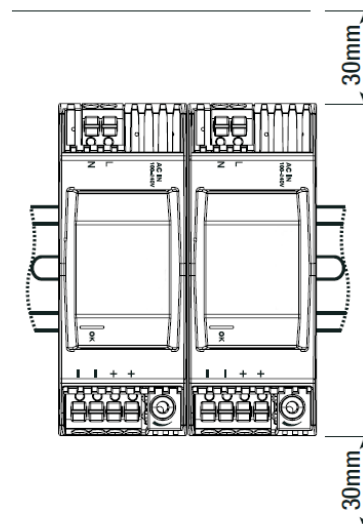

Parallel operation for redundancy 1+1

1. Adjust each power supply to the exact same output voltage with same load and cooling conditions.
2. Use the same wire length and cable cross-section for each power supply (star connection) and energize all units at the same time to avoid triggering overload protection.
3. It must be ensured that each of the power supplies is able to provide the total required output power.
4. **ATTENTION:** For redundant operation required decoupling devices are not included and need to be added externally. (e.g. decoupling diode or DC fuse). Leakage current, EMI, inrush current, harmonics will increase when using multiple power supplies.

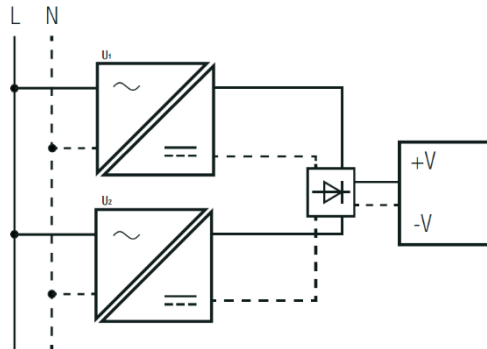

Parallel operation for increasing output power 1+n

1. Adjust each power supply to the exact same output voltage with same load and cooling conditions.
2. Use the same wire length and cable cross-section for each power supply (star connection) and energize all units at the same time to avoid triggering overload protection.
3. For reliable operation a maximum load up to 90% of the total rated power is recommended.
4. **ATTENTION:** To prevent high reverse currents in the event of an output fault, it is recommended to install a protective circuit at the output of each device when more than two power supplies are connected in parallel (e.g. decoupling diode or DC fuse). Leakage current, EMI, inrush current, harmonics will increase when using multiple power supplies.

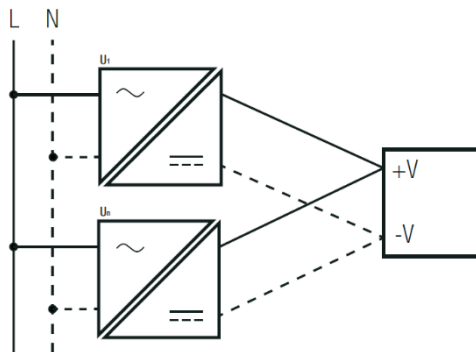

Series Operation

1. Only use PSU with the same type and performance class with identical parameters.
2. To increase the DC output voltage, connect 2 or more power supply units in series. See below table/figures as example.
3. **ATTENTION:** If the power supply units are connected in series, the permanently permissible SELV voltage of max. DC 60V is not guaranteed. Leakage current, EMI, inrush current, harmonics will increase when using multiple power supplies use PSU with the same type and performance class with identical parameters.

Example with 2 PSU's in series:	Figure 1	Figure 2	Figure 3
SDP-90-35024	+48Vdc	-48Vdc	±24Vdc

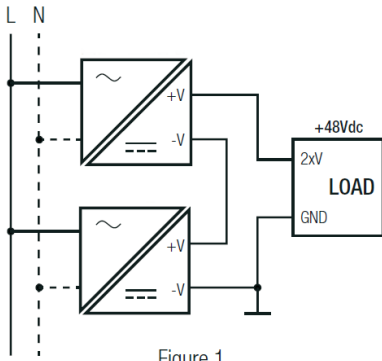

Figure 1

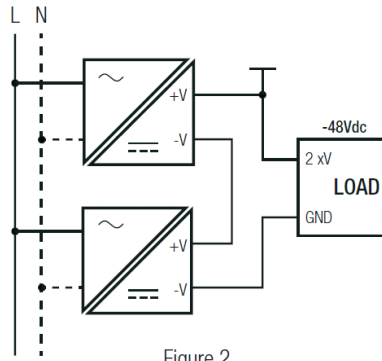

Figure 2

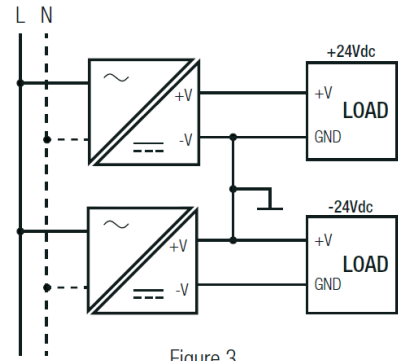
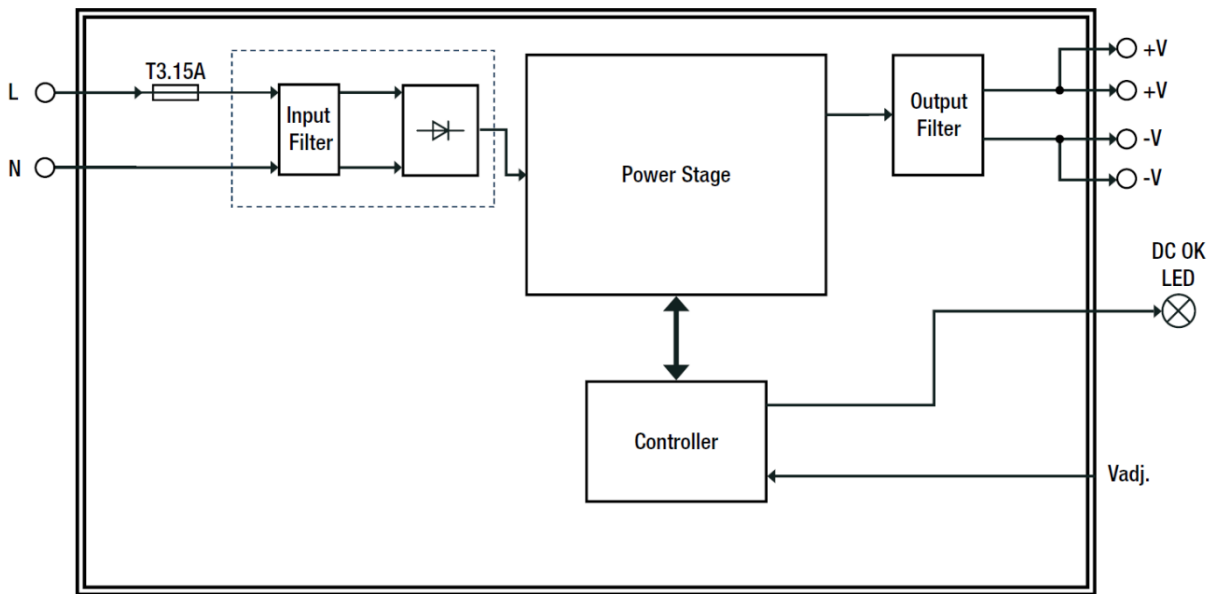

Figure 3

BLOCK DIAGRAM



PACKAGING INFORMATION		
Parameter	Type	Value
Packaging Dimension (LxWxH)	cardboard box	300.0 x 200.0 x 280.0mm
Packaging Quantity		30pcs
Storage Temperature Range		-40°C to +85°C
Storage Humidity	non-condensing	95% RH max.

The product information and specifications may be subject to changes even without prior written notice. The product has been designed for various applications; its suitability lies in the responsibility of each customer. The products are not authorized for use in safety-critical applications without Premium’s explicit written consent. A safety-critical application is an application where a failure may reasonably be expected to endanger or cause loss of life, inflict bodily harm or damage property. The applicant shall indemnify and hold harmless Premium PSU, its affiliated companies and its representatives against any damage claims in connection with the unauthorized use of Premium products in such safety-critical applications