

EFC-240

4-Channel e -fuse

GENERAL FEATURES

- Push-in connectors for tool-less wiring
- Start-Up delay adjustable by switch
- NEC Class 2 limit switchable
- Adjustable power limit & load indication by LED
- Individual ON/OFF and OCP limit for each channel
- Short circuit protection & power boost 150%/5s
- DC input UVLO protection
- DC-OK contacts with remote fault reset
- Overload priority channel protection
- Output hiccup or tripping mode adjustable by switch
- Easy daisy chaining of multiple modules
- Paired Input & output (+, -) connectors included



DESCRIPTION

The EFC series are 4-channel electronic fuse (e-Fuse) load switches with independent overcurrent limit control and real-time output current indication. Each channel is separately protected so that overload or fault conditions on an individual load do not affect overall system reliability or function. The useful LED indicators show the output current and change from green to yellow (current within limit) to orange (current at limit) to red (overcurrent or short-circuit). A volt-free DC-OK output can be used to monitor system function. Each channel can also be switched ON or OFF to ease fault diagnostics or for maintenance.

The Premium PSU e-Fuses EFC-240 are available with 10A maximum channel current and 150% power boost for 5s but can handle 150% overload for up to 120ms to avoid nuisance tripping. The channels power up in sequence to reduce the input inrush current with a pre-settable delay time. Under system overload conditions, the channels will disconnect the loads in reverse sequence, keeping essential functions running to the last. Output overload hiccup or tripping mode is adjustable by a switch.

The e-Fuses have a high lifetime expectancy >80.000h/40°C and easy wiring with tool-less push-in and lever-release terminals. The input and output terminals are also paired to allow easy daisy chaining.

SELECTION GUIDE

Part Number	Input Voltage Range	Output Voltage Range	Output Channels.	Output Current per Channel	Efficiency typ. ⁽¹⁾	rated Output Power per Channel
	[VDC]	[VDC]		[A]	[%]	[W]
EFC-240-32410	22-28	24	4	10	98.6	240

Note1: Efficiency is tested at nominal input 24VDC, 100% load each output and +25°C ambient
t

BASIC CHARACTERISTICS (measured @ T_{AMB}= 25°C, 240VAC full load and after warm-up unless otherwise stated)

Parameter	Condition	Min.	Typ.	Max.
Nominal Input Voltage			24VDC	
Operating Input Range		22VDC		28VDC
Absolute Maximum Input Voltage	no damage to the device			28VDC
Turn-on Voltage			21.5VDC	
Turn-off Voltage	Channel 1		17.5VDC	
	Channel 2		18.5VDC	
	Channel 3		19.5VDC	
	Channel 4		20.5VDC	
Input Current	nom. VIN= 24VDC			40.1A
No Load Power Consumption	nom. VIN= 24VDC		1.5W	
Internal Consumption			60mA	
Nominal Output Voltage			24VDC	
Nominal Output Current (per channel)	nom. VIN= 24VDC		10A	
Output Current Range (adjustable)	via potentiometer at each channel, % of nominal I _{out}	3.5A		11.5A
Voltage Drop	Input to Output			250mV
Minimum Load		0%		
Sequential Switch-ON Delay	selectable via Dip-switch, refer to „DIP-SWITCH SETTINGS“	5ms, 25ms, 200ms or 500ms		
Remote Reset Input (3)	referred to input ground	yes, by applying 22-28VDC		
Ripple and Noise	20MHz bandwidth			105mVp-p
Maximum Capacitive Load				30mF

Note3: Do not connect remote reset input to hazardous voltages!

DIP-SWITCH SETTINGS

DIP1: setting the overcurrent shutdown mode (ON= Latch off mode; OFF= Hiccup Mode)

DIP2: setting the time delay from Channel [k+1] to Channel [k]

DIP3: setting the time delay from Channel [k+1] to Channel [k]

Description	DIP-Switch
Overcurrent shutdown hiccup mode 5ms time delay	
Overcurrent shutdown latching 5ms time delay	
Overcurrent shutdown latching 25ms time delay	
Overcurrent shutdown latching 200ms time delay	
Overcurrent shutdown latching 500ms time delay	
Overcurrent shutdown hiccup mode 500ms time delay	

LOAD INDICATION LED

8 LEDs/channel for displaying actual and target current or various status messages of the corresponding channel. Grey LEDs represent deactivated LEDs.

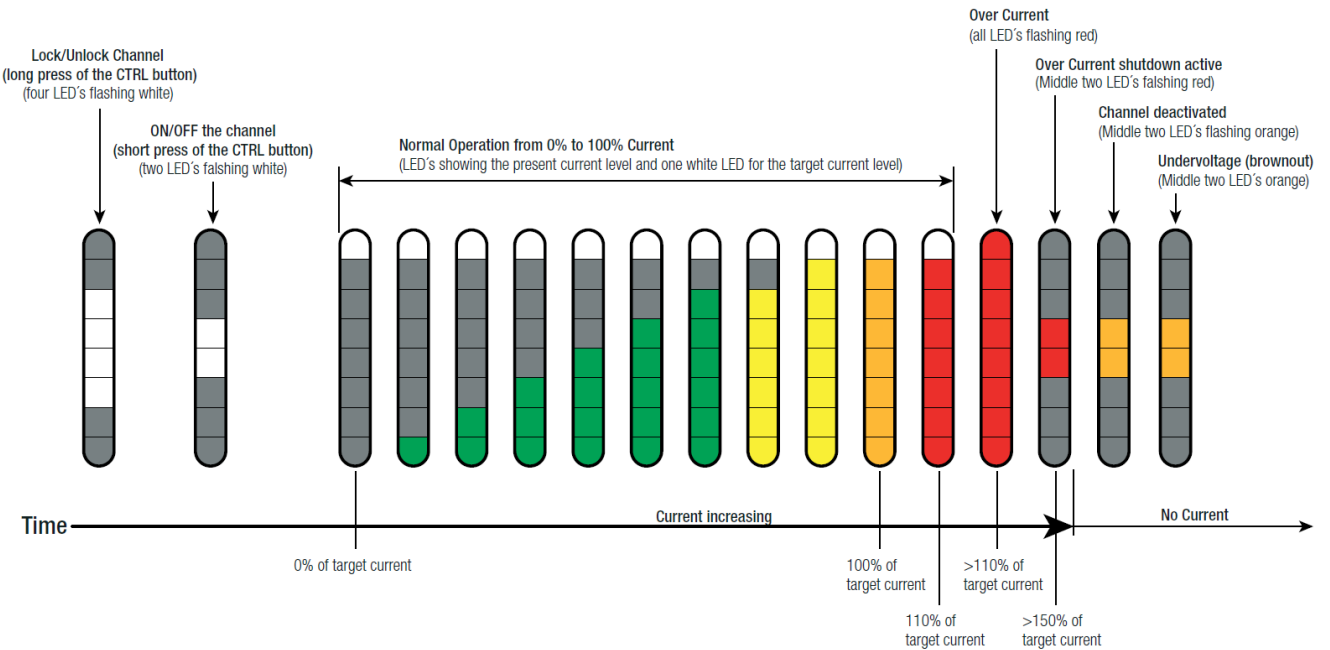

Actual current: Colored LEDs indicate the actual current of 0-110% in relation to the set maximum current. In the picture above the target current is set to it's maximum.
Power Boost: During Operation in >110% and <150% Target Current Level the device stays in Overcurrent for about 5s before the Overcurrent shutdown gets active. If the 150% margin is surpassed (e.g. a short) the over current shutdown will get active after around 120ms.
Target current: White LED indicates the maximum allowable current, which is set by the user via the potentiometer. In above picture the target current is currently set at its maximum value, the nominal current per channel of the device.
Maximum current (Over Current): When actual current > target current, all LEDs from the corresponding channel flash red.
Channel deactivated: When the channel is deactivated, the two middle LEDs flash orange.
Undervoltage: In the event of a brownout (undervoltage), the two middle LEDs light up orange, and the device attempts to automatically restart in a hiccup mode once the voltage is restored.

Control Button

Description	Function	
short press	ON/OFF the channel (during operation) or to restart in latching mode after a short circuit.	
long press (5s)	Lock/Unlock the channel button	

Load LED indications:

Button lock after long press of the button: If the button has been locked/unlocked the four middle LEDs indicate it by flashing white.
Button locked and interaction with the button: If the button has been locked and the button is pressed for a short amount of time (e.g. to disable/ enable a channel), the two middle LEDs indicate it by flashing white, but no action on the channel.

PROTECTIONS (measured @ T_{AMB}= 25°C, nom V_{IN}= 24VDC, rated load, unless otherwise stated)

Parameter	Type	Value
Internal Input Fuse	per channel	T15A, slow-blow
Short Circuit Protection (SCP)	selectable via Dip-switch, refer to „DIP-SWITCH SETTINGS“	latch off or hiccup mode
Over Voltage Protection (OVP)	SELV output	35VDC, latch off
Return Voltage Immunity		35VDC max.
Over Current Protection (OCP)	ff or hiccup mode, selectable via Dip-switch; refer to „DIP-SWITCH SETTINGS“	>5s >150% of rated Output Current
Tripping Characteristic	at short circuit	120ms max.
		5s max. (at 150% load)
Tripping Delay		115ms typ.
Class of Equipment		Class III

ENVIRONMENTAL (measured @ T_{AMB}= 25°C, nom V_{IN}= 24VDC, rated load, unless otherwise stated)

Parameter	Condition		Value
Operating Ambient Temperature Range	@ natural convection (0.1m/s)		-40°C to +70°C
Operating Altitude (4)			5000m
Operating Humidity	non-condensing		5-95% RH max.
Pollution Degree			PD2
IP Rating			IP20
Shock	according to IEC 60068-2-27 Fa	non-operating	15G/11ms, 3 times (positive/negative) in all axis
Vibration	according to IEC 60068-2-6 Fc	non-operating	5 - 8.4Hz @ 3.5mm deflection 8.4 -150Hz @ 2G, 10 cycles /axis(min-max-min); 1 octave/min
MTBF	according to EN/IEC 61709 (SN29500)		770 x 103 hours
Design Lifetime	T _{AMB} = 40°C @ 100% Load		80 x 10 ³ hours

Note4: Recognized by safety agency for safe operation up to 5000m. High altitude operation may impact the performance and lifetime

Derating Graph (per channel)

(@ Chamber and natural convection 0.1m/s)

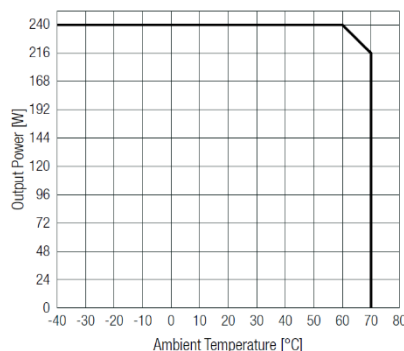

**ENVIRONMENTAL (measured @ T_{AMB}= 25°C, nom V_{IN}= 24VDC, rated load, unless otherwise stated)**

Certificate Type (Safety)	Report Number	Standard
Audio/Video, information and communication technology equipment - Part 1: Safety requirements (CB)		IEC62368-1:2018 3rd Edition
Audio/Video, information and communication technology equipment - Part 1: Safety requirements		EN IEC 62368-1:2020+A11:2020
Audio/Video, information and communication technology equipment - Part 1: Safety requirements		UL62368-1:2019 3rd Edition CAN/CSA-C22.2 No. 62368-1-19 3rd Edition
Electrical Equipment For Measurement, Control, and Laboratory Use; Part 1: General Requirements (CB)		IEC61010-1:2010+A1:2016 3rd Edition
Electrical Equipment For Measurement, Control, and Laboratory Use; Part 1: General Requirements		EN61010-1:2010+A1:2019
Electrical Equipment For Measurement, Control, and Laboratory Use; Part 2-201: Particular requirements for control equipment (CB)		IEC61010-2-201:2017 2nd Edition
Electrical Equipment For Measurement, Control, and Laboratory Use; Part 2-201: Particular requirements for control equipment		EN IEC 61010-2-201:2018
RoHS2		RoHS 2011/65/EU + AM2015/863

EMC Compliance according to IEC/EN61000-6-2/6-3	Condition	Standard / Criterion
Electromagnetic compatibility (EMC) - Part 6-2: Generic standards - Immunity standard for industrial environments		IEC/EN61000-6-2:2019
Electromagnetic compatibility (EMC) - Part 6-3: Generic standards - Emission standard for residential area		IEC/EN 61000-6-3:2021
ESD Electrostatic discharge immunity test	Air: ±8kV; Contact: ±6kV	IEC61000-4-2:2008, Criteria A EN61000-4-2:2009, Criteria A
Radiated, radio-frequency, electromagnetic field immunity test	10V/m (80-6000MHz)	IEC/EN61000-4-3:2006+A2:2010, Criteria A
Fast Transient and Burst Immunity	DC-Input/Output Ports: ±1kV	IEC/EN61000-4-4:2012 Criteria A
Surge Immunity	DC-Input/Output Port: V(+) - V(-), DC-OK(13-14): ±1kV V(+)-PE, V(-)-PE: ±2kV	IEC/EN61000-4-5:2014+A1:2017, Criteria A
Immunity to conducted disturbances, induced by radio-frequency fields	10Vrms (0.15-80MHz)	IEC61000-4-6:2013, Criteria A EN61000-4-6:2014, Criteria A

DIMENSION & PHYSICAL CHARACTERISTICS

Parameter	Type	Value
Material	chassis	polycarbonate (UL94 V-0)
Dimension (HxWxD)		110.2 x 72.0 x 61.9mm 4.34 x 2.83 x 2.44 inch
Weight		250g 0.55 lbs

Dimension Drawing (mm)

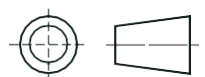

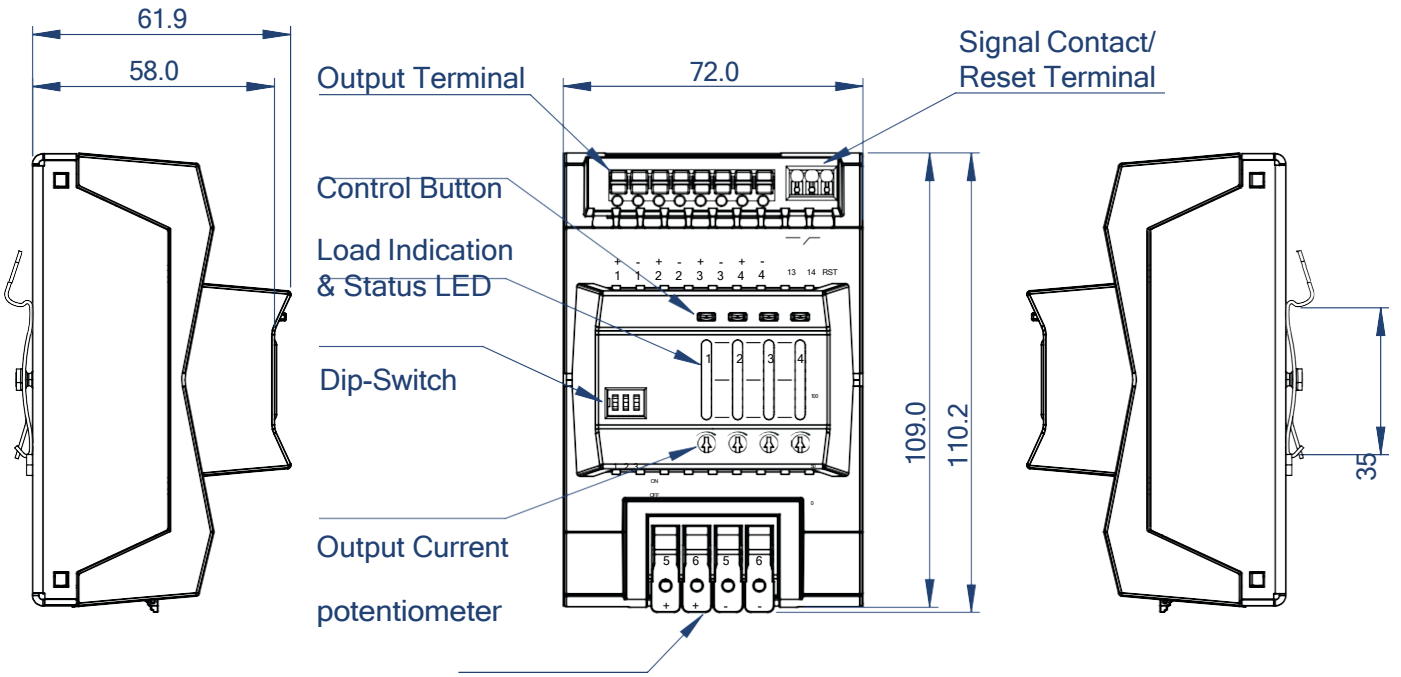

Input Terminal

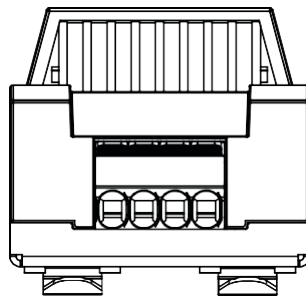

Input Cage Clamp		
Function	AWG	mm ²
+Vin	24-8	0.25-6
-Vin	24-8	0.25-6
Wire stripping length: 12-13mm		

Push-In Output Terminal ⁽⁶⁾		
Function	AWG	mm ²
-Vout	20-12	0.5-4
+Vout	20-12	0.5-4
Wire stripping length: 10-11mm		

Push-In Signal/Reset Terminal ⁽⁶⁾		
Function	AWG	mm ²
Signal	28-16	0.25-1.5
Wire stripping length: 8-9mm		
Do not connect to hazardous voltages		

Note5: Use flexible (stranded wire) or solid cables with above wire cross-section is recommended.
 Use copper conductors designed for an operating temperature of at least 105°C.
 Note6: Ferrules are required for flexible cable

Mounting Instruction

Mounting Rail: Standard TS35 DIN Rail in accordance with EN 60715.
 No space above, below and between the devices are required.

Mounting

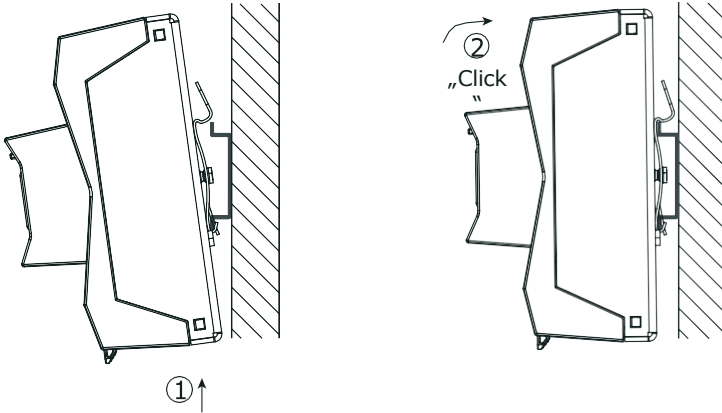

1. Place the device on the DIN rail with a slight downward tilt.
2. Tilt the device upwards until it reaches the upper part of the DIN rail. Snap the device into the DIN rail.

Release

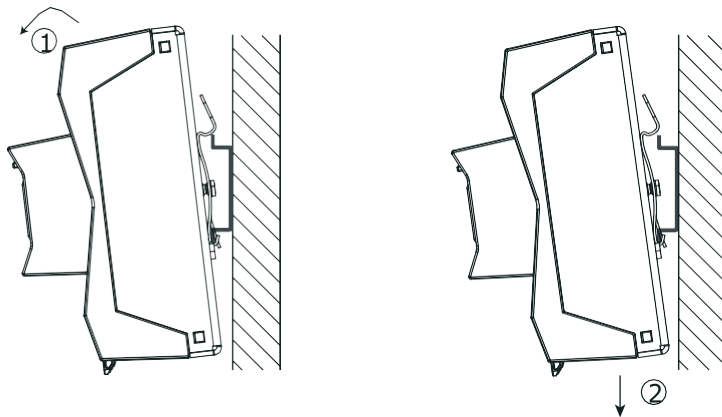

1. Press the upper part of the device forwards to release it from the rail.
2. Pull the device away from the DIN rail by pushing it down.

BLOCK DIAGRAM

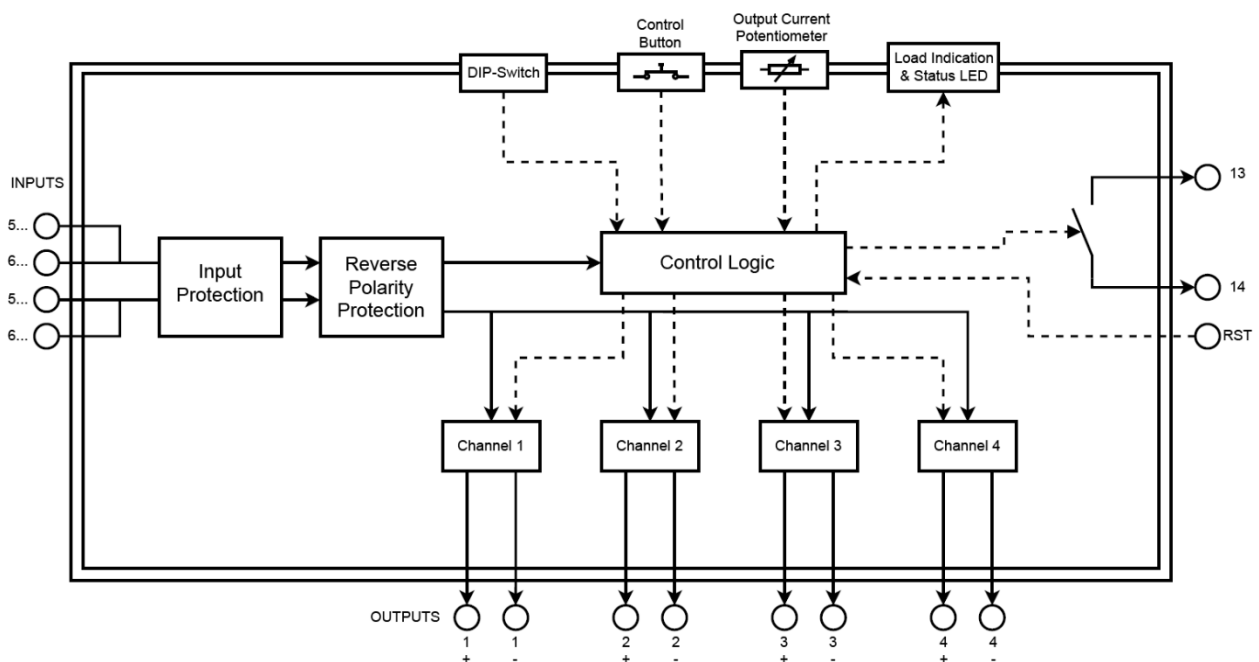

APPLICATION EXAMPLE

Daisy Chaining of multiple modules

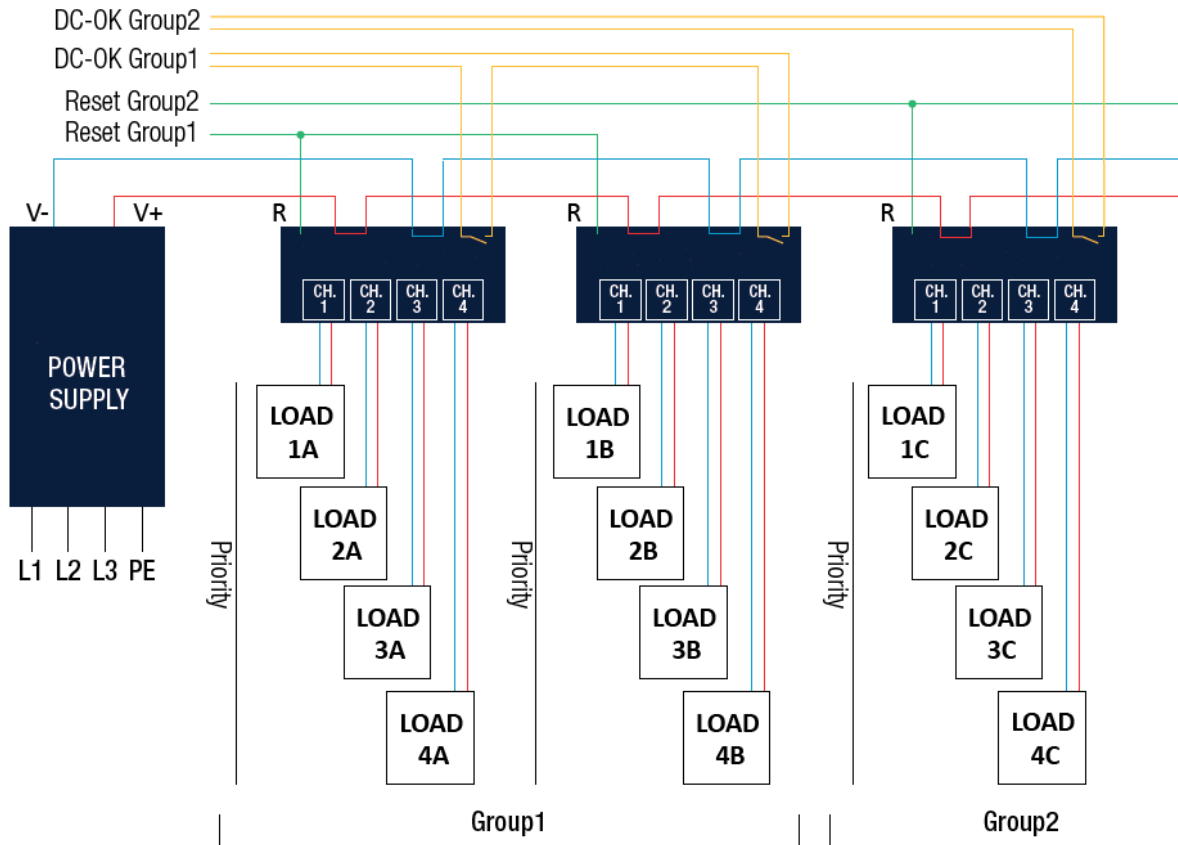

- Voltage-free relay contact for DC-OK signal (closed when all active channels are "OK", open in error mode (one channel or several channels
- switched off due to overload or UVLO)
- DC-OK can be connected in series with other e-fuse modules for group monitoring
- In latch mode, the e-Fuses can be switched on again by remote resets

PACKAGING INFORMATION

Parameter	Type	Value
Packaging Dimension (LxWxH)	cardboard box	153 x 97 x 78mm
Packaging Quantity		1 pc
Storage Temperature Range		-40°C to +85°C
Storage Humidity	non-condensing	95% RH max.

The product information and specifications may be subject to changes even without prior written notice. The product has been designed for various applications; its suitability lies in the responsibility of each customer. The products are not authorized for use in safety-critical applications without PREMIUM's explicit written consent. A safety-critical application is an application where a failure may reasonably be expected to endanger or cause loss of life, inflict bodily harm or damage property. The applicant shall indemnify and hold harmless PREMIUM S.A., its affiliated companies and its representatives against any damage claims in connection with the unauthorized use of Premium PSU products in such safety-critical applications.