

DPX-960

DIN-Rail Power Supply 960W ◊ Input: 3AC 400-480V

GENERAL FEATURES

- Slim Design (80mm) with 25° Push-In connectors
- Fast tool-less mounting and demounting
- PFC >0.9 and Active Inrush Current Limitation
- DC-Input Range 430V to 815V/850V 10s
- Highest Efficiency up to 97.1%
- Full Power -40°C/+60°C, Boost Power 150%/6s
- Thermal Power Bonus up to 120%/45°C
- Charging & Parallel Operation
- Highest Lifetime Expectancy 80.000h/40°C
- DC-OK-Signal
- Reduced no load power consumption 2.1W-2.7W
- Extended surge immunity 2.5kV/6kV



DESCRIPTION

The slim DPX-960 is a high reliability, three phase AC input DIN rail mount power supply with 24V and 48V output variations in extremely compact dimensions of 135 x 155.7mm with a width of only 80mm. It is specially designed for demanding applications in the harsh industrial automation field with an extended mains input surge immunity of up to 6kV and return voltage immunity >35/63V at the output making it suitable for safe operation against back feeding loads like decelerating motors and inductors. These units will deliver up to 960W over the full -40°C to +60°C ambient temperature range with only convection cooling. A Thermal Power Bonus of up to 1152W at 45°C plus a power boost of up to 150% for 6s makes them suitable for powering highly inductive or capacitive loads. The unique and innovative modern design with 25° push-in connectors allows easy tool-less installation or replacement. The product is certified according to the global safety standards IEC/EN/UL 62368-1, IEC/EN/UL 61010-1 and IEC/EN/UL/CSA 61010-2-201. Electromagnetic radiated and conducted emissions are compliant to heavy industrial EN 61000-6-4 Class B emission standard and EN 61000-6-2 immunity standard.

SELECTION GUIDE

| Part Number | Input Voltage Range [VDC] | Output Voltage nom. [VDC] | Adjustable Output Voltage [VDC] | Output Current nom. [A] | Efficiency ⁽¹⁾ Typ [%] | Rated Output Power ⁽²⁾ [W] |
|----------------|---------------------------|---------------------------|---------------------------------|-------------------------|-----------------------------------|---------------------------------------|
| DPX-960-35824T | 3 x 320-575 | 24 | 24-28 | 40 | 96 | 960 |
| DPX-960-35848T | 3 x 320-575 | 48 | 48-56 | 20 | 97 | 960 |

Note1: Efficiency is tested at nominal input (400/480VAC) and full load at +25°C ambient.

Note2: Thermal Power Bonus (TAMB= 45°C max.) 120% for DPX-960-35848T; 110% for DPX-960-35824T, and Boost Power 150%/6sec max. refer to "Boost Power".

ACCESSORIES

| Part Number | Description |
|---------------|---|
| EFC-120-32405 | electronic circuit breaker; 4-channel; input voltage DC 24 V adjustable output current 1.75-5.75A and selectable NEC Class 2 mode |
| EFC-240-32410 | electronic circuit breaker; 4-channel; input voltage DC 24 V; adjustable output current 3.5-11.5A |

| BASIC CHARACTERISTICS (measured @ T _{AMB} = 25°C, 3AC 400VAC full load and after warm-up unless otherwise stated) | | | | |
|--|---|----------------|--------|----------------------------|
| Parameter | Condition | Min. | Typ. | Max. |
| Nominal Input Voltage | 50/60Hz | 400Vac | | 480VAC |
| Operating Range (3) | 3 phase operation (4) | 320VAC | | 575VAC |
| | 2 phase operation, max. P _{OUT} = 600W | 350VAC | | 480VAC |
| | DC input refer to „Connections for DC-operation“ | continuous | 450VDC | 815VDC |
| | | 10s max. | | 850VDC |
| Turn-on Voltage | prevents switching on during 1AC operation | 300VAC | | |
| | DC operation | 424VDC | | |
| Turn-off Voltage | AC operation | 290VAC | | |
| | DC operation | 410VDC | | |
| Input Current | AC operation | 400VAC | | 3x 1.6A |
| | | 480VAC | | 3x 1.4A |
| | DC operation | 500VDC | | 2.1A |
| Inrush Current | 3AC 400VAC, cold start | | | 10A |
| No Load Power Consumption | 3AC 400VAC | DPX-960-35824T | 2.2W | 3W |
| | | DPX-960-35848T | 2.1W | |
| | 3AC 480VAC | DPX-960-35824T | 2.5W | |
| | | DPX-960-35848T | 2.7W | |
| Input Frequency Range | | 47Hz | | 63Hz |
| Nominal Output Voltage (factory set) | DPX-960-35824T | | 24VDC | |
| | DPX-960-35848T | | 48VDC | |
| Minimum Load | | 0% | | |
| Power Factor | 400VAC, full load | | 0.94 | |
| Start-up time | 2 & 3 phase operation, 400VAC | | 695ms | 810ms |
| Rise time | | | 5ms | 10ms |
| Hold-up time | DPX-960-35824T | | 23ms | |
| | DPX-960-35848T | | 21ms | |
| Internal Operating Frequency | | | 83kHz | |
| Ripple and Noise | 20MHz bandwidth | | | 1% of nom V _{OUT} |

Note3: The products were submitted for safety files at AC and DC-Input operation. (350V-575VAC and 450-600VDC)
If input voltage is >500VDC consider an external fuse according to applicable standards.

2phase operation is not included in the safety approvals. Additional tests might be necessary when the complete application has to be approved according to UL 62368-1, 61010-1 and UL 61010-2-201.

Note4: Output power derating for Line-input of less than 3AC 350VAC (derate linearly from 100% at 350VAC to 90% at 3AC 320VAC)

Connections for DC-operation

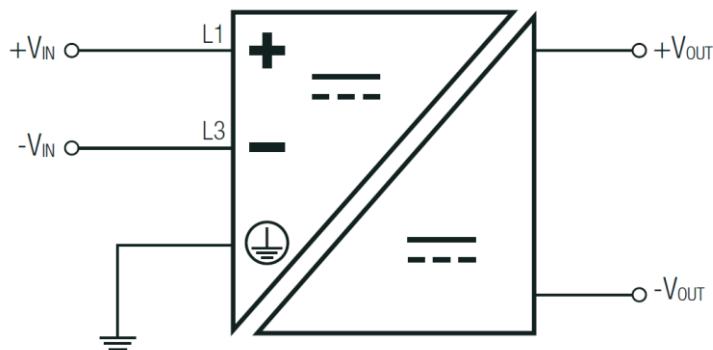



BASIC CHARACTERISTICS (measured @ T_{AMB}= 25°C, 3AC 400VAC full load and after warm-up unless otherwise stated)

DPX-960-35824T

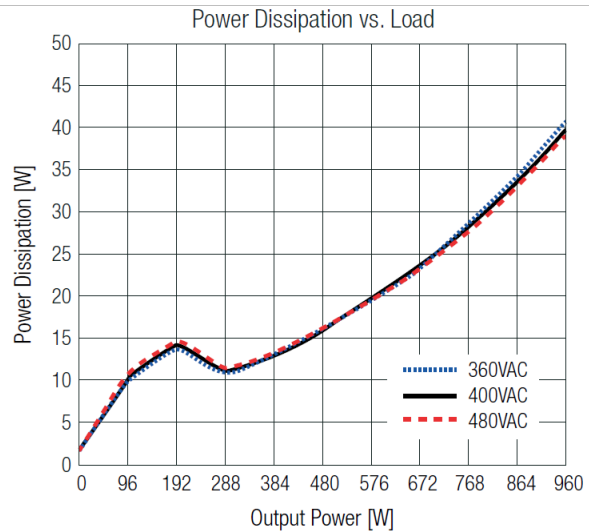
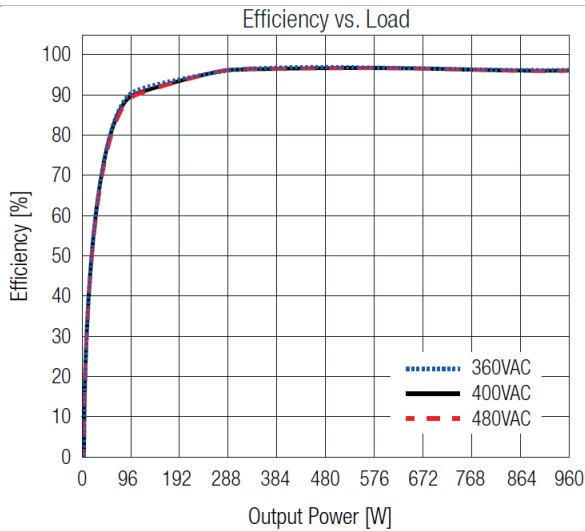

DPX-960-35848T

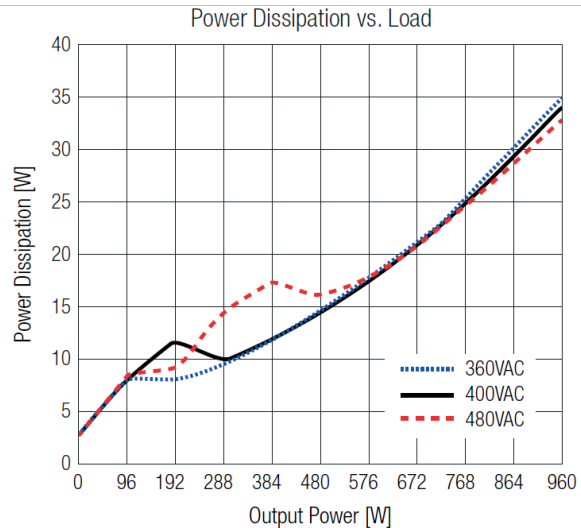
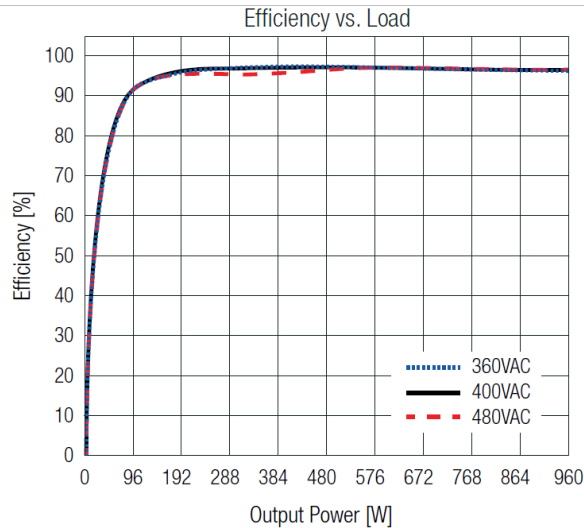

Additional Features

| Parameter meter | Condition | | Value |
|----------------------------------|--|----------------|--|
| Output Voltage Adjustability (5) | on-board potentiometer | DPX-960-35824T | 24-28VDC |
| | | DPX-960-35848T | 48-56VDC |
| Parallel Load Share Mode | refer to „DIP-SWITCH SETTINGS“ | | |
| Boost Power (Factory set) | refer to "Boost Power" | | 150% for 6s |
| | | | 250% for 20ms |
| Charging Mode | DIP-Switch 2 "ON"; limited to T _{AMB} max. 60°C, to maintain reliability Refer to „CC/CV Mode (Charging Mode)“ | | typ. 100% IOUTLIMIT continuous |
| Load Indication LED | LED green, refer to „Load Indication LED“ | | normal mode |
| | LED off | | abnormal mode, no operation or failure |
| DC-OK LED | LED green | | output voltage ok, normal mode |
| | LED off | | abnormal mode, no operation or failure |
| Signal Contact | closed | | normal mode |
| | open | | abnormal mode, no operation or failure |
| Signal Contact Rating | do not connect signaling contact to hazardous voltages | DPX-960-35824T | 30VDC/0.1A |
| | | DPX-960-35848T | 60VDC/0.1A |

Note5: When input voltage is below 350VAC, the output voltage is limited to 24/48VDC.

Make sure that the maximum rated output power will not be exceeded when trimming up.

| DIP-SWITCH SETTINGS | | | |
|---|------|------|--|
| | DIP1 | DIP2 | |
| <p>Single Mode (Factory set) Power Boost Mode available, refer to „Boost Power“</p> | OFF | OFF | |
| <p>Parallel Load Share Mode Angled output characteristic for load sharing. Voltage drop from 0 to nom. IO_{UT}: 1.2V</p> | ON | OFF | |
| <p>Charging Mode Current Limitation strictly at nominal current. Refer to „CC/CV Mode (Charging Mode)“ For battery charging, please get in contact with PREMIUM PSU techsupport.</p> | OFF | ON | |
| <p>Not allowed!</p> | ON | ON | |

U/I Factory Setting (Single Mode)

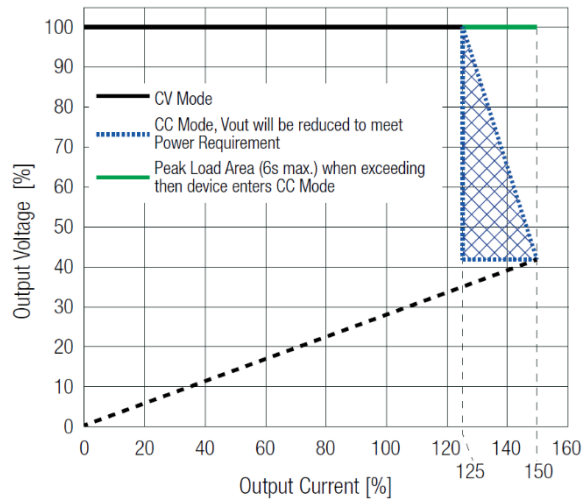

CC/CV Mode (Charging Mode)

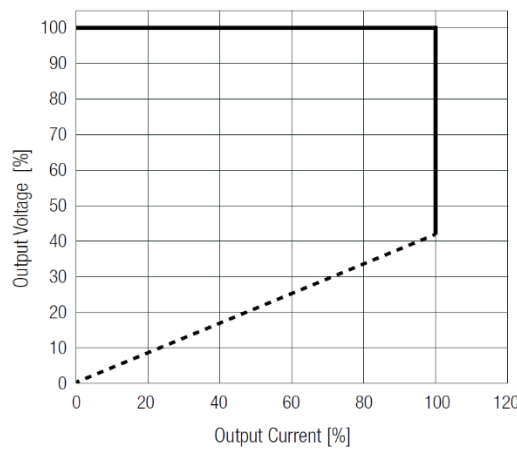



LOAD INDICATION LED

4 LEDs displaying actual and target current of rated output current.

0 25 50 75 100
% of rated I_{OUT}

REGULATIONS (measured @ T_{amb} = 25°C, 3AC 400VAC full load and after warm-up unless otherwise stated)

| Parameter | Conditions | Value |
|---------------------------------|----------------------------------|------------|
| Output Accuracy | | ±1.0% max. |
| Line Regulation | low line to high line, full load | ±0.1% typ. |
| Load Regulation | 0% to 100% load | ±0.3% typ. |
| Max. Capacitive Load (start-up) | DPX-960-35824T | 40mF |
| | DPX-960-35848T | 20mF |
| Transient Response | 10-100% load | ±3.0% typ. |
| | recovery time | 100ms typ. |

PROTECTIONS (measured @ T_{amb} = 25°C, 3AC 400VAC full load and after warm-up unless otherwise stated)

| Parameter | Type | Value | |
|---|----------------------|---|--------------------|
| Internal Input Fuse | DC compliant | 2x T5A, slow-blow | |
| Easy Fuse Tripping | | 250%/20ms | |
| External Input Protection | | 16A C-characteristic circuit breaker | |
| Short Circuit Protection (SCP) | | hiccup mode, auto recovery | |
| Over Voltage Protection (OVP) | SELV output | DPX-960-35824T | 35VDC, latch off |
| | | DPX-960-35848T | 59.8VDC, latch off |
| Return Voltage Immunity | continuous | DPX-960-35824T | 35VDC max. |
| | | DPX-960-35848T | 63VDC max. |
| | <5 min | DPX-960-35824T | 38VDC |
| | | DPX-960-35848T | 68VDC |
| Absorbing Energy | DPX-960-35824T | 2J | |
| | DPX-960-35848T | 1.5J | |
| Over Current Protection (OCP) | <6 sec | >150% of rated load current, hiccup mode, auto recovery | |
| | <20ms ⁽⁶⁾ | >250% of rated load current, hiccup mode, auto recovery | |
| Class of Equipment | | Class I with PE connection | |
| Isolation Voltage (safety certified) ⁽⁷⁾ | tested for 1 minute | I/P to O/P | 3.5kVAC / 5kVDC |
| | | I/P to PE | 1.6kVAC / 2.5kVDC |
| | | O/P to PE | 500VAC / 700VDC |
| Isolation Resistance | I/P to O/P | 4.5MΩ min. | |
| Insulation Grade | | reinforced | |
| Earth Leakage Current | 480VAC/60Hz | 3.5mA max. | |

Note6: V_{OUT} = 19VDC min.

Note7: For repeat Hi-Pot testing, reduce the time and/or the test voltage



| ENVIRONMENTAL (measured @ TAMB= 25°C, 3AC 400VAC full load and after warm-up unless otherwise stated) | | | |
|---|-------------------------------------|------------------|---|
| Parameter | Condition | | Value |
| Operating Ambient Temperature Range | @ natural convection (0.1m/s) | with derating | -40°C to +70°C |
| | | without derating | refer to „Derating Graph“ |
| Operating Altitude ⁽⁸⁾ | | | 5000m |
| Operating Humidity | non-condensing | | 95% RH max. |
| Pollution Degree | | | PD2 |
| IP Rating | | | IP20 |
| Shock | according to IEC 60068-2-27 Fa | non-operating | 15G/11ms, 3 times (positive/negative) in all axis |
| Vibration | according to IEC 60068-2-6 Fc | non-operating | 5 - 8.4Hz @ 3.5mm deflection 8.4 -150Hz @ 2G, 10 cycles /axis(min-max-min); 1 octave/min |
| MTBF | according to EN/IEC 61709 (SN29500) | | 680 x 103 hours |
| Design Lifetime | TAMB= 40°C @ 100% Load | | 80 x 10 ³ hours |

Note8: Recognized by safety agency for safe operation up to 5000m. High altitude operation may impact the performance and lifetime

Derating Graph

(@ Chamber and natural convection 0.1m/s)

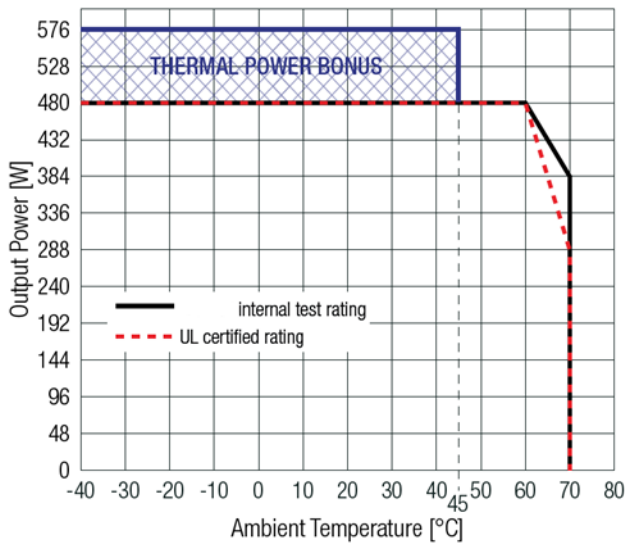

Boost Power

(400V-480VAC or 500VDC; -40°C to +60°C max.)

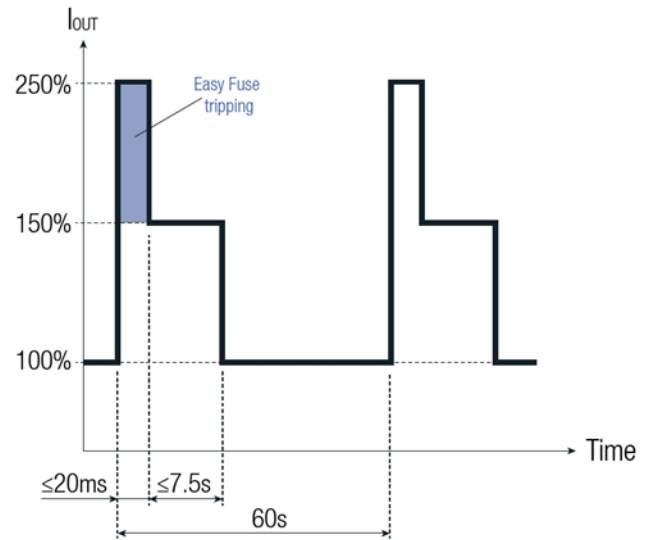

Boost Power

(400V-480VAC or 500VDC; -40°C to +60°C max.)

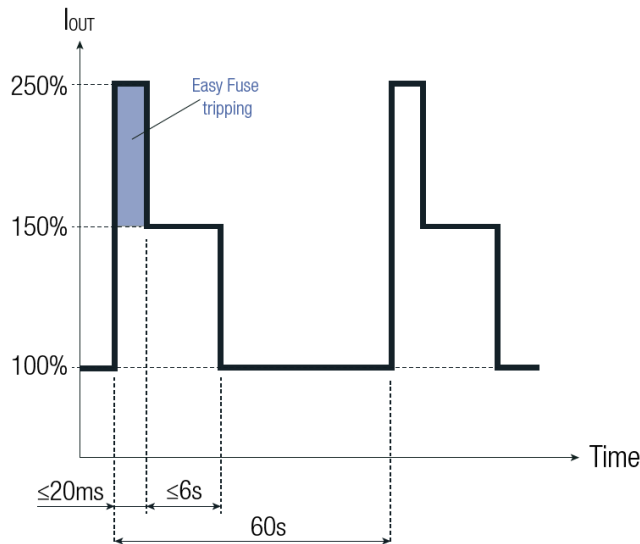



| SAFETY & CERTIFICATIONS | | |
|---|---------------|--|
| Certificate Type (Safety) | Report Number | Standard |
| Audio/Video, information and communication technology equipment - Part 1: Safety requirements (CB) | | IEC62368-1:2018 3rd Edition |
| Audio/Video, information and communication technology equipment - Part 1: Safety requirements | | EN IEC 62368-1:2020+A11:2020 |
| Audio/Video, information and communication technology equipment - Part 1: Safety requirements | | UL62368-1:2019 3rd Edition CAN/CSA-C22.2 No. 62368-1-19 3rd Edition |
| Electrical Equipment For Measurement, Control, and Laboratory Use; Part 1: General Requirements (CB) | | IEC61010-1:2010+A1:2016 3rd Edition |
| Electrical Equipment For Measurement, Control, and Laboratory Use; Part 1: General Requirements | | EN61010-1:2010+A1:2019 |
| Electrical Equipment For Measurement, Control, and Laboratory Use; Part 1: General Requirements | | UL61010-1:2012 3rd Edition CAN/CSA-C22.2 No. 61010-1-12 3rd Edition |
| Electrical Equipment For Measurement, Control, and Laboratory Use; Part 2-201: Particular requirements for control equipment (CB) | | IEC61010-2-201:2017 2nd Edition |
| Electrical Equipment For Measurement, Control, and Laboratory Use; Part 2-201: Particular requirements for control equipment | | EN IEC 61010-2-201:2018 |
| Electrical Equipment For Measurement, Control, and Laboratory Use; Part 2-201: Particular requirements for control equipment | | UL61010-2-201:2018 2nd Edition CAN/CSA-C22.2 No. 61010-2-201:2018-02-01 |
| RoHS2 | | RoHS 2011/65/EU + AM2015/863 |

| EMC Compliance according to IEC/EN61000-6-4/6-2 | Condition | | Standard / Criterion |
|---|---|---|---|
| Electromagnetic compatibility (EMC) - Part 6-2: Generic standards - Immunity standard for industrial environments | | | IEC/EN61000-6-2:2019 |
| Electromagnetic compatibility (EMC) - Part 6-3: Generic standards - Emission standard for residential area | | | IEC/EN 61000-6-3:2021 |
| ESD Electrostatic discharge immunity test | Air: ±8kV; Contact: ±6kV | | IEC61000-4-2:2008, Criteria A EN61000-4-2:2009, Criteria A |
| Radiated, radio-frequency, electromagnetic field immunity test | 10V/m (80-1000MHz) | | IEC/EN61000-4-3:2006+A2:2010, Criteria A |
| Fast Transient and Burst Immunity | AC Power Port: ±4kV DC-Output Port: ±2kV | | IEC/EN61000-4-4:2012, Criteria A |
| Surge Immunity | AC-Power Port: L1-L2, L1-L3, L2-L3: ±2.5kV L1-PE,L2-PE,L3-PE: ±6kV | | IEC/EN61000-4-5:2014+A1:2017, Criteria A |
| | DC-Output Port: Vout(+) - Vout(-), DC-OK(13-14): ±1kV Vout(+)-PE, Vout(-)-PE: ±2kV | | |
| Immunity to conducted disturbances, induced by radio-frequency fields | 10Vrms (0.15-80MHz) | | IEC61000-4-6:2013, Criteria A EN61000-4-6:2014, Criteria A |
| Power Magnetic Field Immunity | 30A/m, 50/60Hz | | EN61000-4-8:2010, Criteria A |
| Voltage Dips | 400VAC, 50Hz | 100%, 5 cycle; 70%, 10 cycles; 40%, 25 cycles; 30%, 25 cycles | IEC61000-4-11:2004+A1:2017, Criteria B |
| Voltage Interruptions | 400VAC, 50Hz | 100%, 250 cycles | IEC61000-4-11:2004+A1:2017, Criteria B |
| Limits of Harmonic Current Emissions | | | EN IEC 61000-3-2:2019 |
| Limits of Voltage Fluctuations & Flicker | | | EN61000-3-3:2013+A1:2017 |



DIMENSION & PHYSICAL CHARACTERISTICS

| Parameter | Type | Value |
|-------------------|---------|---|
| Material | chassis | polycarbonate / aluminum |
| Dimension (HxWxD) | | 135.0 x 80.0 x 155.7mm 5.3 x 3.15 x 6.1 inch |
| Weight | | 1140g 2.51 lbs |

Dimension Drawing (mm)

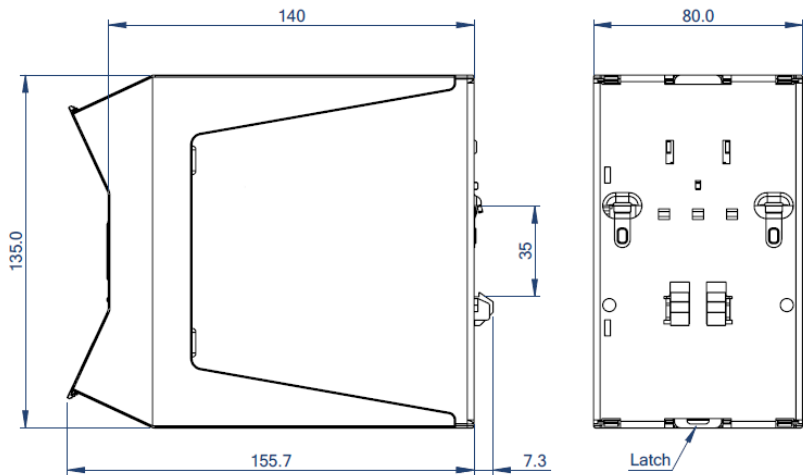
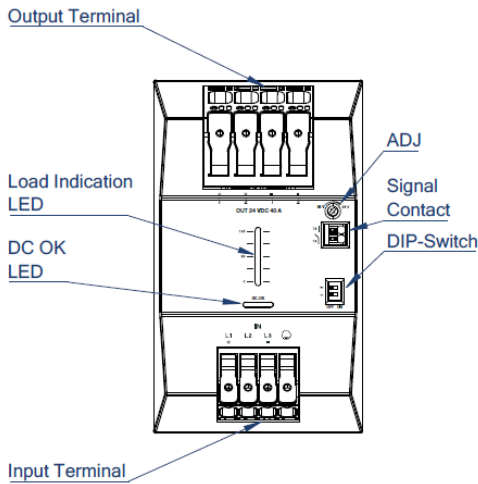
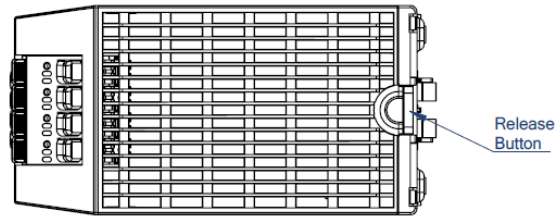

Input & Output Cage Clamp

| Function | AWG | mm ² |
|--------------------------------|------|------------------------|
| L1, L2, L3 | 24-8 | 0.25-6 |
| PE | 24-8 | 0.25-6 |
| Wire stripping length: 12-13mm | | |
| +1, +2 (Vout) | 18-4 | 0.75-25mm ² |
| -1, -2 (Vout) | 18-4 | 0.75-25mm ² |
| Wire stripping length: 18-20mm | | |

Push-In Signal Terminal ⁽⁹⁾

| Function | AWG | mm ² |
|------------------------------|-------|-----------------|
| Signal (13,14) | 24-16 | 0.25-1.5 |
| Wire stripping length: 8-9mm | | |

Do not connect signaling contact to hazardous voltages

Note8: Use flexible (stranded wire) or solid cables with above wire cross-section is recommended.

Use copper conductors designed for an operating temperature of at least 90°C.

Note9: Ferrules are required for flexible cable.

Tolerance: ±0.5mm

Installation Instructions

Mounting Instruction

Mounting Rail: Standard TS35 DIN Rail in accordance with EN 60715.

Mounting

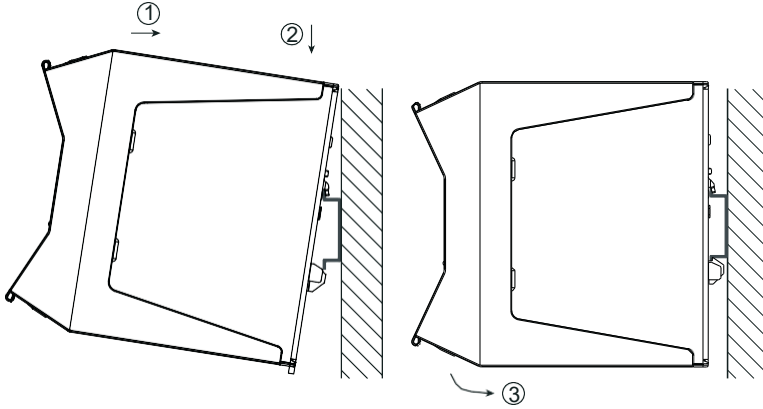

1. Place the device on the DIN rail with a slight upward tilt. Snap the device into the DIN rail.
2. Now tilt the device downwards until it reaches the lower part of the DIN rail.
3. Press the lower part of the device firmly against the rail until the device locks into position on the DIN rail.
4. To make sure it is securely locked in place, give the device a gentle shake.

Release Option 1 (tool-less)

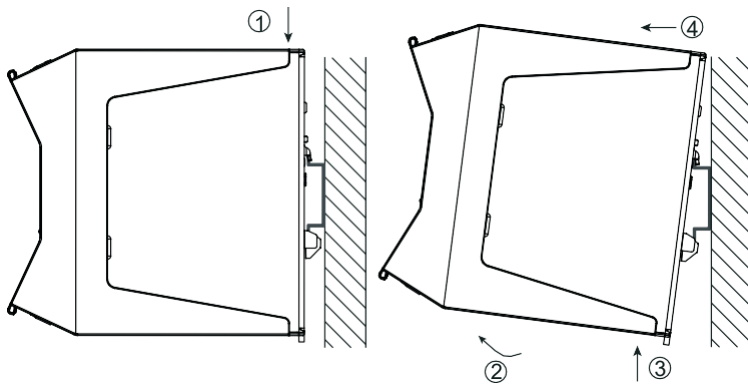

1. Press the unlock button on the top of the device to release the latch from the rail.
2. While pushing the button, slightly tilt the device forward.
3. Pull the device away from the DIN rail by pushing it up.
4. Remove the power supply completely from the rail.

Release Option 2 (by using a screwdriver)

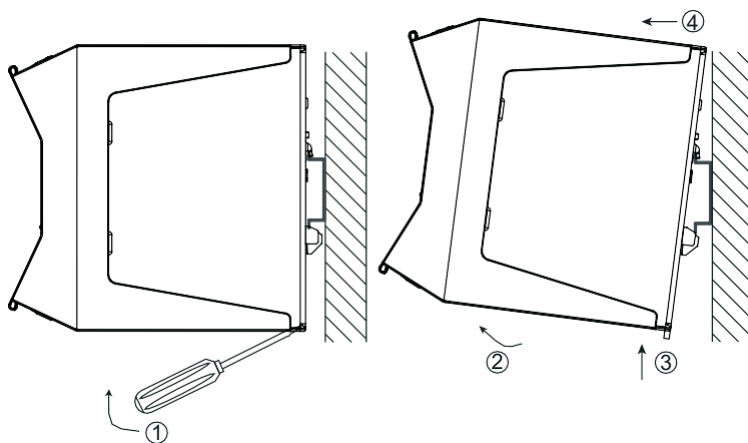

1. Pull the DIN rail latch by using a screwdriver OUT of the device and HOLD it.
2. Tilt the bottom of the device OUT.
3. Pull the device away from the DIN rail by pushing it up.
4. Remove the power supply completely from the rail

Installation Instructions

To guarantee sufficient convection cooling, keep a distance of 20mm above and 40mm below the device.

For vertical mounting the device should be installed with the input terminal on the bottom.

No space between supplies are required.

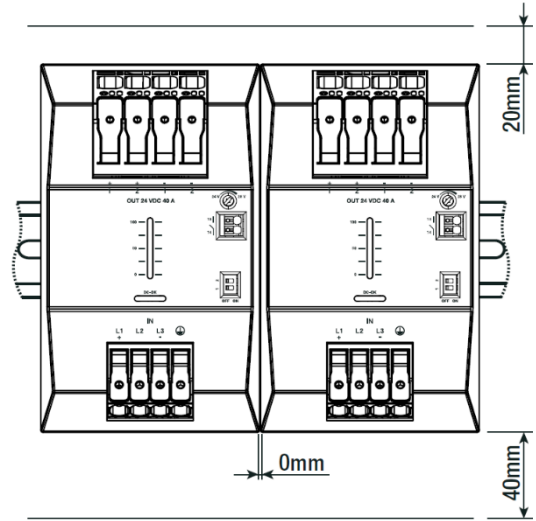

Phase redundancy

- 1) If one phase fails, operation is still guaranteed. (2-phase operation)

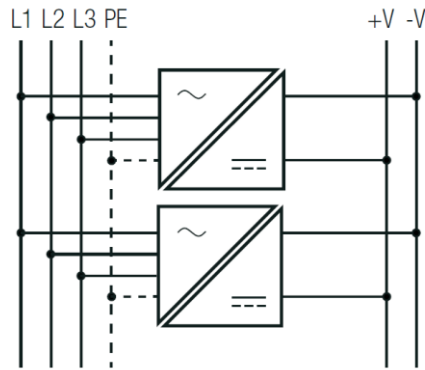

Parallel Operation

- 1) Make sure that the DIP-Switch 1 is "ON" to get into the Parallel Load sharing mode.
- 2) Adjust each power supply to the exact same output voltage with same load and cooling conditions.
- 2) Use the same wire length and cable cross-section for each power supply (star connection) and energize all units at the same time to avoid triggering overload protection.
- 3) Do not use power supplies in parallel in mounting orientations other than the standard mounting orientation (input terminals on the bottom of the unit) or in any other condition where a derating of the output current is required (e.g. above 60°C, ...).
- 4) Pay attention that leakage current, EMI, inrush current, harmonics will increase when using multiple power supplies.

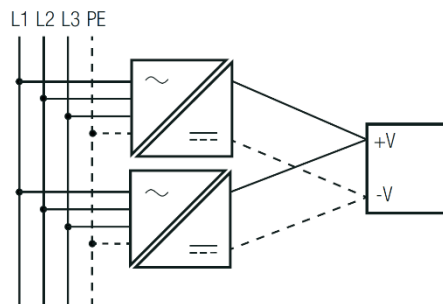

BLOCK DIAGRAM

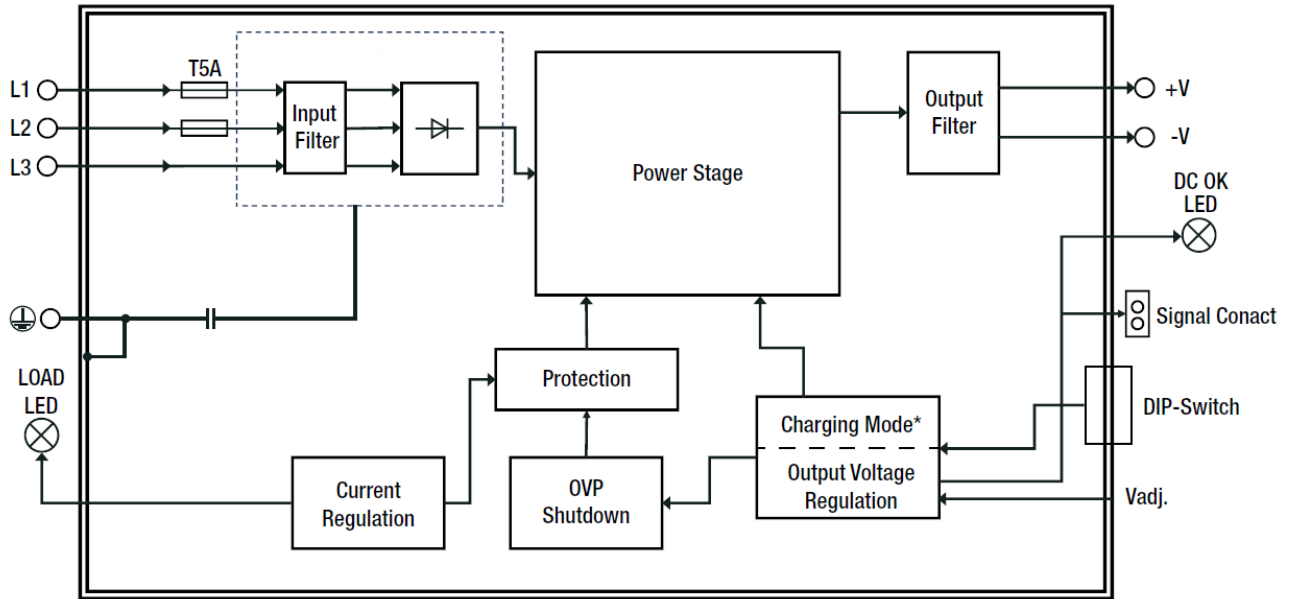

PACKAGING INFORMATION

| Parameter | Type | Value |
|-----------------------------|----------------|------------------|
| Packaging Dimension (LxWxH) | cardboard box | 180 x 175 x 96mm |
| Packaging Quantity | | 1 pc |
| Storage Temperature Range | | -40°C to +85°C |
| Storage Humidity | non-condensing | 85% RH max. |

The product information and specifications may be subject to changes even without prior written notice. The product has been designed for various applications; its suitability lies in the responsibility of each customer. The products are not authorized for use in safety-critical applications without Premium's explicit written consent. A safety-critical application is an application where a failure may reasonably be expected to endanger or cause loss of life, inflict bodily harm or damage property. The applicant shall indemnify and hold harmless Premium PSU, its affiliated companies and its representatives against any damage claims in connection with the unauthorized use of Premium products in such safety-critical applications