

DPX-480

DIN-Rail Power Supply 480W ◊ Input: 3AC 400-480V

GENERAL FEATURES

- Slim Design (52mm) with 25° Push-In connectors
- Fast tool-less mounting and demounting
- PFC >0.9 and Active Inrush Current Limitation
- DC-Input Range 430V to 815V/850V 10s
- Highest Efficiency up to 95.3%
- Full Power -40°C/+60°C, Boost Power 150%/7.5s
- Thermal Power Bonus 120%/45°C
- Charging & Parallel Operation
- Highest Lifetime Expectancy 80.000h/40°C
- DC-OK-Signal
- Reduced no load power consumption 1.9W-3W
- Extended surge immunity 2.5kV/6kV



DESCRIPTION

The slim DPX-480 is a high reliability, three phase AC input DIN rail mount power supply with 24V and 48V output variations in extremely compact dimensions of 135 x 155.7mm with a width of only 52mm. It is specially designed for demanding applications in the harsh industrial automation field with an extended mains input surge immunity of up to 6kV and return voltage immunity >35/63V at the output making it suitable for safe operation against back feeding loads like decelerating motors and inductors. These units will deliver up to 480W over the full -40°C to +60°C ambient temperature range with only convection cooling. A Thermal Power Bonus of up to 576W at 45°C plus a power boost of up to 150% for 7.5s makes them suitable for powering highly inductive or capacitive loads. The unique and innovative modern design with 25° push-in connectors allows easy tool-less installation or replacement. The product is certified according to the global safety standards IEC/EN/UL 62368-1, IEC/EN/UL 61010-1 and IEC/EN/UL/CSA 61010-2-201. Electromagnetic radiated and conducted emissions are compliant to heavy industrial EN 61000-6-4 Class B emission standard and EN 61000-6-2 immunity standard.

SELECTION GUIDE

Part Number	Input Voltage Range [VDC]	Output Voltage nom. [VDC]	Adjustable Output Voltage [VDC]	Output Current nom. [A]	Efficiency ⁽¹⁾ Typ [%]	Rated Output Power ⁽²⁾ [W]
DPX-480-35724	3x 320-575	24	24-28	20	95	480
DPX-480-35748	3x 320-575	48	48-56	10	94	480

Note1: Efficiency is tested at nominal input (400/480VAC) and full load at +25°C ambient.

Note2: Thermal Power Bonus 120% (TAMB= 45°C max.), and Boost Power 150%/7.5sec max.; refer to "Boost Power".

ACCESSORIES	
Part Number	Description
EFC-120-32405	electronic circuit breaker; 4-channel; input voltage DC 24 V adjustable output current 1.75-5.75A and selectable NEC Class 2 mode
EFC-240-32410	electronic circuit breaker; 4-channel; input voltage DC 24 V; adjustable output current 3.5-11.5A

BASIC CHARACTERISTICS (measured @ T_{AMB}= 25°C, 3AC 400VAC full load and after warm-up unless otherwise stated)					
Parameter	Condition		Min.	Typ.	Max.
Nominal Input Voltage	50/60Hz		400VAC		480VAC
Operating Range (3)	3 phase operation (4)		320VAC		575VAC
	2 phase operation, max. POUT= 340W		350VAC		480VAC
	DC input refer to "Connections for DC- operation"	continuous	450VDC		815VDC
10s max.				850VDC	
Turn-on Voltage	prevents switching on during 1AC operation		310VAC		
	DC operation		440VDC		
Turn-off Voltage	AC operation		280VAC		
	DC operation		395VDC		
Input Current	AC operation	400VAC			3x 0.8A
		480VAC			3x 0.7A
	DC operation	500VDC			1.0A
Inrush Current	3AC 400VAC, cold start				10A
No Load Power Consumption	3AC 400VAC	DPX-480-35724T		1.9W	3W
		DPX-480-35748T		2.4W	
	3AC 480VAC	DPX-480-35724T		2W	
		DPX-480-35748T		2.9W	
Input Frequency Range			47Hz		63Hz
Nominal Output Voltage (factory set)	DPX-480-35724			24Vdc	
	DPX-480-35748			48Vdc	
Minimum Load			0%		
Power Factor	full load			0.92	
Start-up time	2 & 3 phase operation, 400VAC			98ms	112ms
Rise time				3.5ms	7ms
Hold-up time	400VAC			15ms	
	480VAC			30ms	
Internal Operating Frequency				83kHz	
Ripple and Noise	20MHz bandwidth				1% of nom VOUT

Note3: The products were submitted for safety files at AC and DC-Input operation. (350V-575VAC and 450-600VDC)

If input voltage is >500VDC consider an external fuse according to applicable standards.

2phase operation is not included in the safety approvals. Additional tests might be necessary when the complete application has to be approved according to UL 62368-1, 61010-1 and UL 61010-2-201.

Note4: Output power derating for Line-input of less than 3AC 350VAC (derate linearly from 100% at 350VAC to 90% at 3AC 320VAC)

Connections for DC-operation

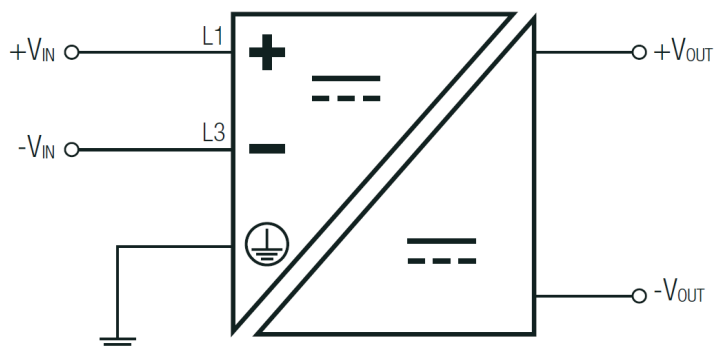



BASIC CHARACTERISTICS (measured @ T_{AMB}= 25°C, 3AC 400VAC full load and after warm-up unless otherwise stated)

DPX-480-35724

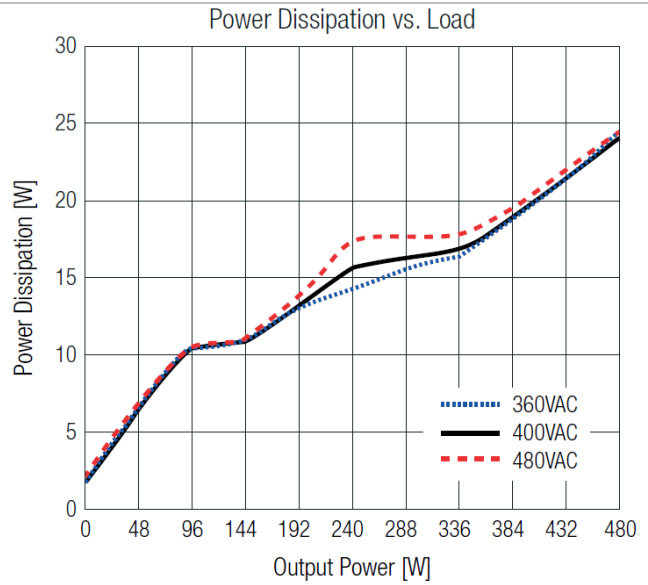
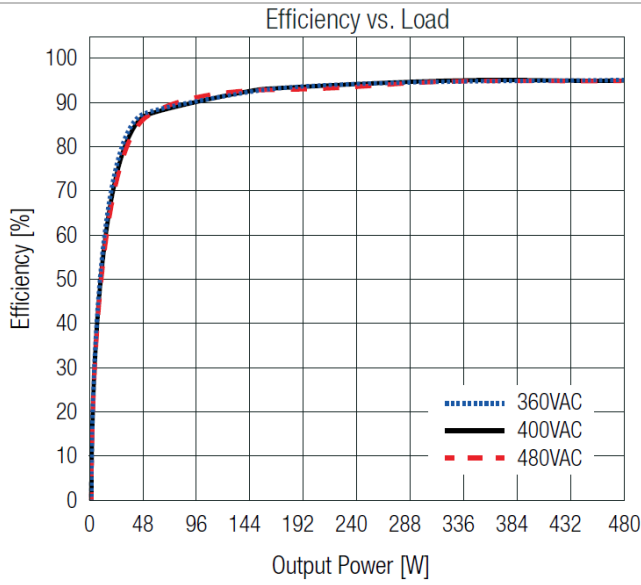

DPX-480-35748

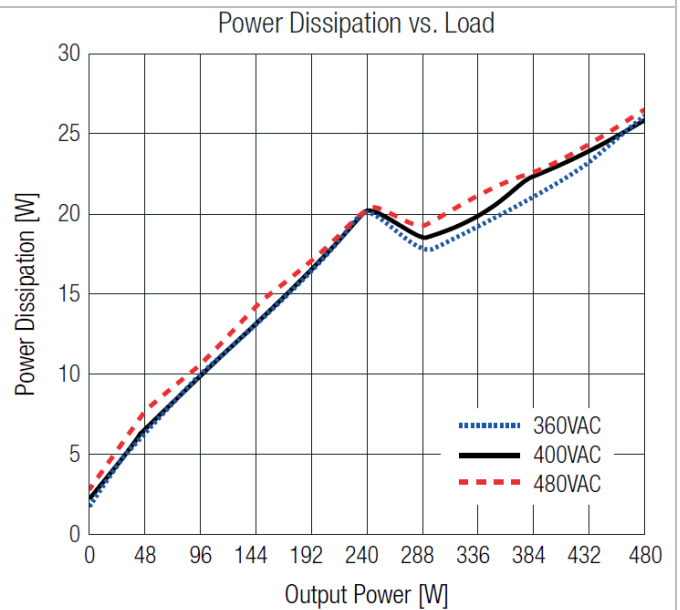
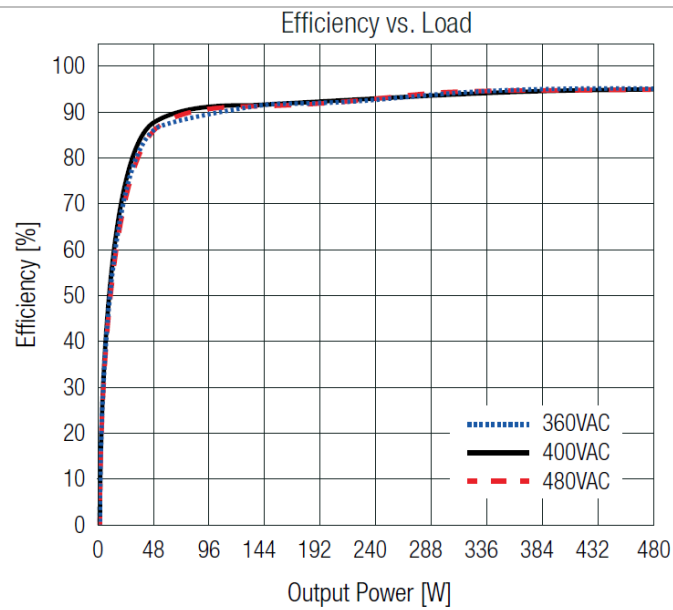

ADDITIONAL FEATURES			
Parameter	Condition		Value
Output Voltage Adjustability (5)	on-board potentiometer	DPX-480-35724T	24-28VDC
		DPX-480-35748T	48-56VDC
Parallel Load Share Mode	refer to „DIP-SWITCH SETTINGS“		
Boost Power (Factory set)	refer to “Boost Power”		150% for 7.5s
			250% for 20ms
Charging Mode	DIP-Switch 2 “ON”; limited to TAMB max. 60°C, to maintain reliability Refer to “CC/CV Mode (Charging Mode)”		typ. 100% IOU TLIMIT continuous
Load Indication LED	LED green, refer to “Load Indication LED”		normal mode
	LED off		abnormal mode, no operation or failure
DC-OK LED	LED green		output voltage ok, normal mode
	LED off		abnormal mode, no operation or failure
Signal Contact	closed		normal mode
	open		abnormal mode, no operation or failure
Signal Contact Rating	Do not connect signaling contact to hazardous voltages	DPX-480-35724T	30VDC/0.1A
		DPX-480-35748T	60VDC/0.1A

Note5: When input voltage is below 350VAC, the output voltage is limited to 24/48VDC.
 Make sure that the maximum rated output power will not be exceeded when trimming up.

DIP-SWITCH SETTINGS

	DIP1	DIP2	
<p>Single Mode (Factory set) Power Boost Mode available, refer to “Boost Power”</p>	OFF	OFF	
<p>Parallel Load Share Mode Angled output characteristic for load sharing. Voltage drop from 0 to nom. IOU T: 1.2V</p>	ON	OFF	
<p>Charging Mode Current Limitation strictly at nominal current. Refer to “CC/CV Mode (Charging Mode)” For battery charging, please get in contact with PREMIUM PSU techsupport.</p>	OFF	ON	
<p>Not allowed!</p>	ON	ON	



U/I Factory Setting (Single Mode)

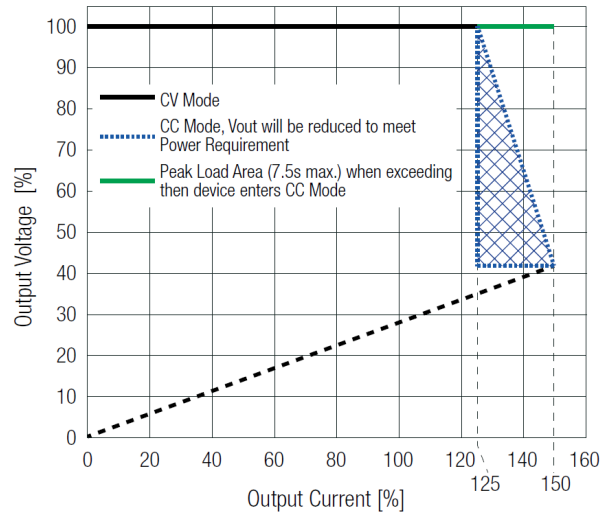

CC/CV Mode (Charging Mode)

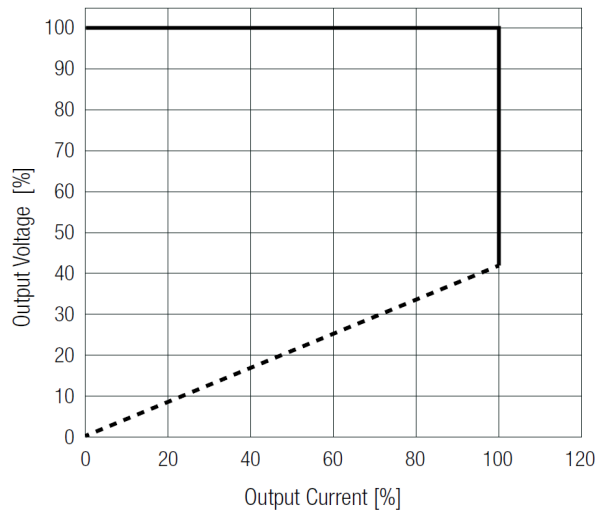

LOAD INDICATION LED

4 LEDs displaying actual and target current of rated output current.

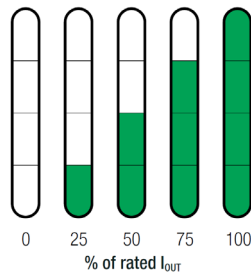

REGULATIONS (measured @ $T_{amb} = 25^{\circ}C$, 3AC 400VAC full load and after warm-up unless otherwise stated)

Parameter	Conditions	Value
Output Accuracy		$\pm 1.0\%$ max.
Line Regulation	low line to high line, full load	$\pm 0.1\%$ typ.
Load Regulation	0% to 100% load	$\pm 0.3\%$ typ.
Max. Capacitive Load (start-up)	DPX-480-35724	40mF
	DPX-480-35748	20mF
Transient Response	10-100% load	$\pm 3.0\%$ typ.
	recovery time	100ms typ.



PROTECTIONS (measured @ T _{amb} = 25°C, 3AC 400VAC full load and after warm-up unless otherwise stated)			
Parameter	Type		Value
Internal Input Fuse	DC compliant		2x T5A, slow-blow
Easy Fuse Tripping			250%/20ms
External Input Protection			16A C-characteristic circuit breaker
Short Circuit Protection (SCP)			hiccup mode, auto recovery
Over Voltage Protection (OVP)	SELV output	DPX-480 /24	35VDC, latch off
		DPX-480 /48	59.8VDC, latch off
Return Voltage Immunity	continuous	DPX-480 /24	35VDC max.
		DPX-480 /48	63VDC max.
	<5 min	DPX-480 /24	38VDC
		DPX-480 /48	68VDC
Absorbing Energy	DPX-480 /24		2J
	DPX-480 /48		1.5J
Over Voltage Category (OVC)			OVC II
Over Current Protection (OCP)	<7.5 sec		>150% of rated load current, hiccup mode, auto recovery
	<20ms (6)		>250% of rated load current, hiccup mode, auto recovery
Class of Equipment			Class I with PE connection
Isolation Voltage (safety certified) (7)	tested for 1 minute	I/P to O/P	3.5kVAC / 5kVDC
		I/P to PE	1.6kVAC / 2.5kVDC
		O/P to PE	500VAC / 700VDC
Isolation Resistance	I/P to O/P		4.5MΩ min.
Insulation Grade			reinforced
Earth Leakage Current	480VAC/60Hz		3.5mA max.

Note6: VOUT= 19VDC min.

Note7: For repeat Hi-Pot testing, reduce the time and/or the test voltage

ENVIRONMENTAL (measured @ T _{amb} = 25°C, 3AC 400VAC full load and after warm-up unless otherwise stated)			
Parameter	Condition		Value
Operating Ambient Temperature Range cy	@ natural convection (0.1m/s)	With derating	-40°C to +70°C
		Without derating	refer to „Derating Graph“
Operating Altitude (7)			5000m
Operating Humidity	non-condensing		95% RH max.
Pollution Degree			PD2
IP Rating			IP20
Shock	according to IEC 60068-2-27 Fa	Non-operating	15G/11ms, 3 times (positive/negative) in all axis
Vibration	according to IEC 60068-2-6 Fc	Non-operating	5 - 8.4Hz @ 3.5mm deflection 8.4 -150Hz @ 2G, 10 cycles /axis(min-max-min); 1 octave/min
MTBF	according to EN/IEC 61709 (SN29500)		705 x 103 hours
Design Lifetime	TAMB= 40°C @ 100% Load		80 x 10 ³ hours

Note7: Recognized by safety agency for safe operation up to 5000m. High altitude operation may impact the performance and lifetime



Derating Graph
(@ Chamber and natural convection 0.1m/s)

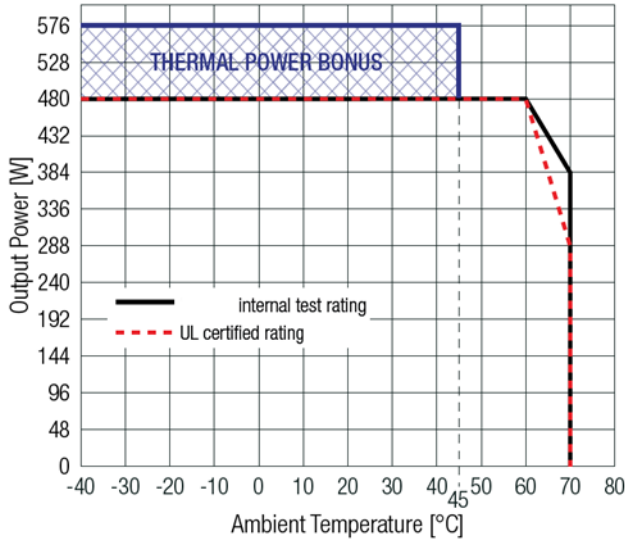

Boost Power
(400V-480VAC or 500VDC; -40°C to +60°C max.)

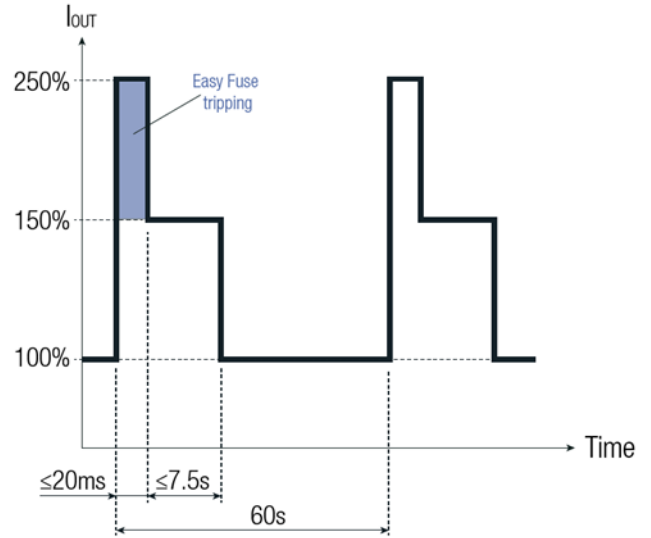

SAFETY & CERTIFICATIONS

Certificate Type (Safety)	Report Number	Standard
Audio/Video, information and communication technology equipment - Part 1: Safety requirements (CB)		IEC62368-1:2018 3rd Edition
Audio/Video, information and communication technology equipment - Part 1: Safety requirements		EN IEC 62368-1:2020+A11:2020
Audio/Video, information and communication technology equipment - Part 1: Safety requirements		UL62368-1:2019 3rd Edition CAN/CSA-C22.2 No. 62368-1-19 3rd Edition
Electrical Equipment For Measurement, Control, and Laboratory Use; Part 1: General Requirements (CB)		IEC61010-1:2010+A1:2016 3rd Edition
Electrical Equipment For Measurement, Control, and Laboratory Use; Part 1: General Requirements		EN61010-1:2010+A1:2019
Electrical Equipment For Measurement, Control, and Laboratory Use; Part 1: General Requirements		UL61010-1:2012 3rd Edition CAN/CSA-C22.2 No. 61010-1-12 3rd Edition
Electrical Equipment For Measurement, Control, and Laboratory Use; Part 2-201: Particular requirements for control equipment (CB)		IEC61010-2-201:2017 2nd Edition
Electrical Equipment For Measurement, Control, and Laboratory Use; Part 2-201: Particular requirements for control equipment		EN IEC 61010-2-201:2018
Electrical Equipment For Measurement, Control, and Laboratory Use; Part 2-201: Particular requirements for control equipment		UL61010-2-201:2018 2nd Edition CAN/CSA-C22.2 No. 61010-2-201:2018-02-01
RoHS2		RoHS 2011/65/EU + AM2015/863



EMC Compliance according to IEC/EN61000-6-4/6-2	Condition		Standard / Criterion
Electromagnetic compatibility (EMC) - Part 6-2: Generic standards - Immunity standard for industrial environments			IEC/EN61000-6-2:2019
Electromagnetic compatibility (EMC) - Part 6-3: Generic standards - Emission standard for residential area			IEC/EN 61000-6-3:2021
ESD Electrostatic discharge immunity test	Air: ±8kV; Contact: ±6kV		IEC61000-4-2:2008, Criteria A EN61000-4-2:2009, Criteria A
Radiated, radio-frequency, electromagnetic field immunity test	10V/m (80-1000MHz)		IEC/EN61000-4-3:2006+A2:2010, Criteria A
Fast Transient and Burst Immunity	AC Power Port: ±4kV DC- Output Port: ±2kV		IEC/EN61000-4-4:2012, Criteria A
Surge Immunity	AC-Power Port: L1-L2, L1-L3, L2-L3: ±2.5kV L1-PE, L2-PE, L3-PE: ±6kV		IEC/EN61000-4-5:2014+A1:2017, Criteria A
	DC-Output Port: Vout(+) - Vout(-), DC-OK(13-14): ±1kV Vout(+)-PE, Vout(-)-PE: ±2kV		
Immunity to conducted disturbances, induced by radio-frequency fields	10Vrms (0.15-80MHz)		IEC61000-4-6:2013, Criteria A EN61000-4-6:2014, Criteria A
Power Magnetic Field Immunity	30A/m, 50/60Hz		EN61000-4-8:2010, Criteria A
Voltage Dips	400VAC, 50Hz	100%, 5 cycle; 70%, 10 cycles; 40%, 25 cycles; 30%, 25 cycles	IEC61000-4-11:2004+A1:2017, Criteria B
Voltage Interruptions	400VAC, 50Hz	100%, 250 cycles	IEC61000-4-11:2004+A1:2017, Criteria B
Limits of Harmonic Current Emissions			EN IEC 61000-3-2:2019
Limits of Voltage Fluctuations & Flicker			EN61000-3-3:2013+A1:2017

DIMENSION & PHYSICAL CHARACTERISTICS

Parameter	Type	Value
Material	chassis	polycarbonate / aluminum
Dimension (HxWxD)		135.0 x 52.0 x 155.7mm 5.3 x 2.0 x 6.1 inch
Weight		768g 1.69 lbs



Dimension Drawing (mm)

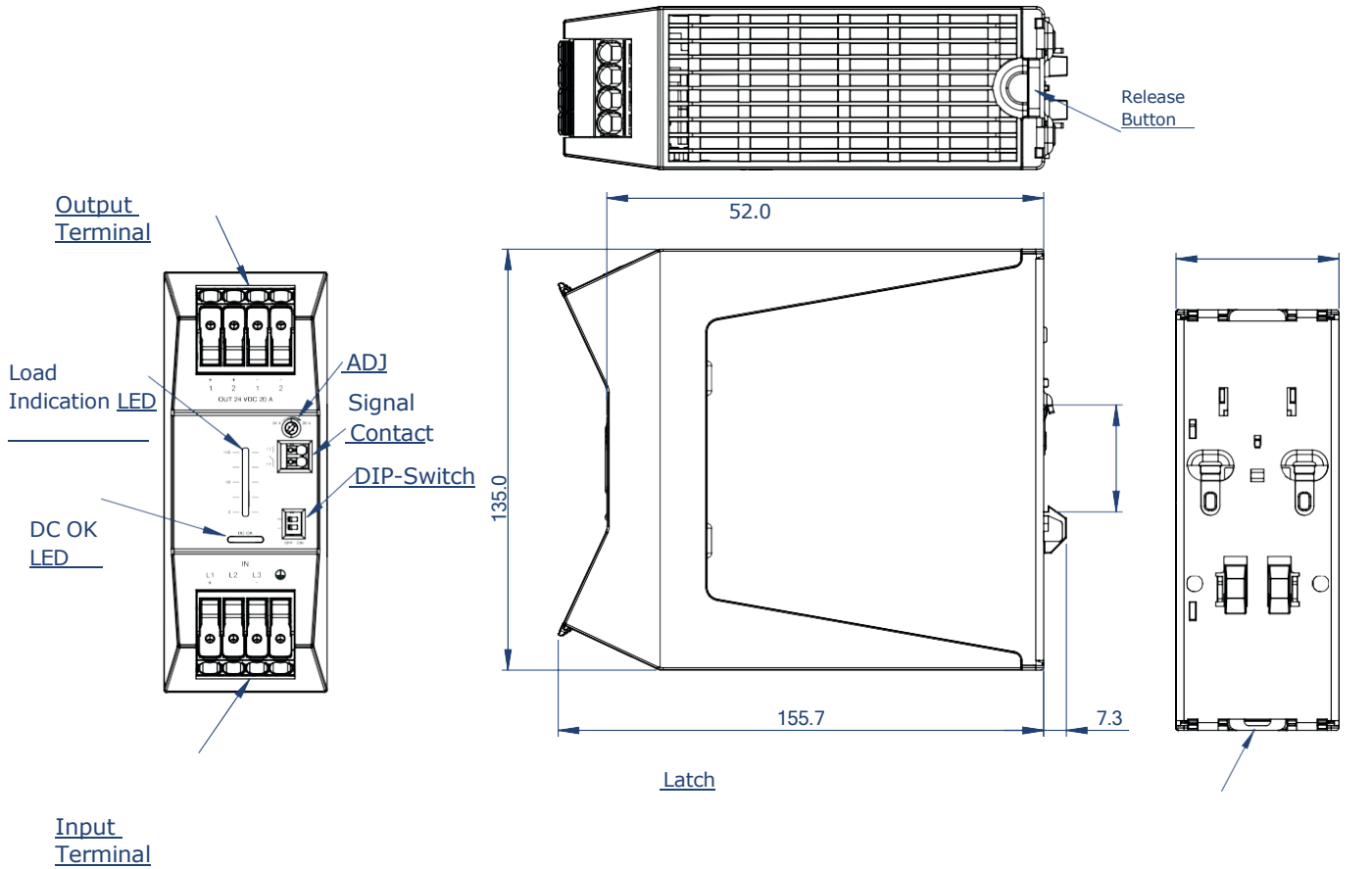
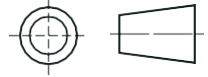

Input & Output Cage Clamp

Function	AWG	mm ²
L1, L2, L3	24-8	0.25-6
PE \oplus	24-8	0.25-6
+1, +2 (Vout)	24-8	0.25-6
-1, -2 (Vout)	24-8	0.25-6
Wire stripping length: 12-13mm		

Push-In Signal Terminal ⁽⁹⁾

Function	AWG	mm ²
Signal (13,14)	24-16	0.25-1.5
Wire stripping length: 8-9mm		

Do not connect signaling contact to hazardous voltages

Note8: Use flexible (stranded wire) or solid cables with above wire cross-section is recommended.

Use copper conductors designed for an operating temperature of at least 90°C.

Note9: Ferrules are required for flexible cable.

Tolerance: ±0.5mm

Installation Instructions

Mounting Instruction

Mounting Rail: Standard TS35 DIN Rail in accordance with EN 60715.

Mounting

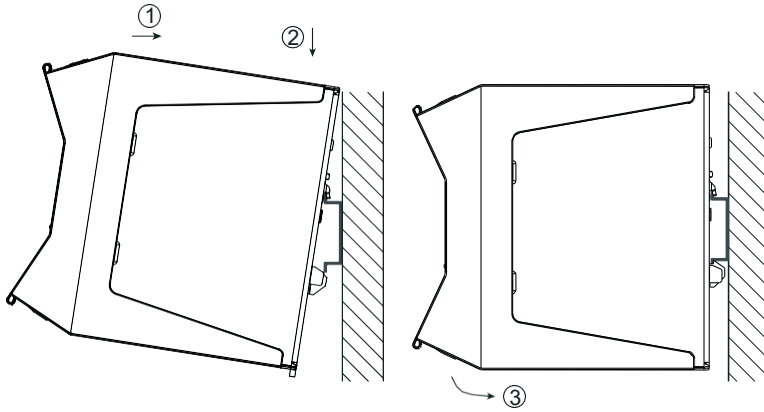

1. Place the device on the DIN rail with a slight upward tilt. Snap the device into the DIN rail.
2. Now tilt the device downwards until it reaches the lower part of the DIN rail.
3. Press the lower part of the device firmly against the rail until the device locks into position on the DIN rail.
4. To make sure it is securely locked in place, give the device a gentle shake.

Release Option 1 (tool-less)

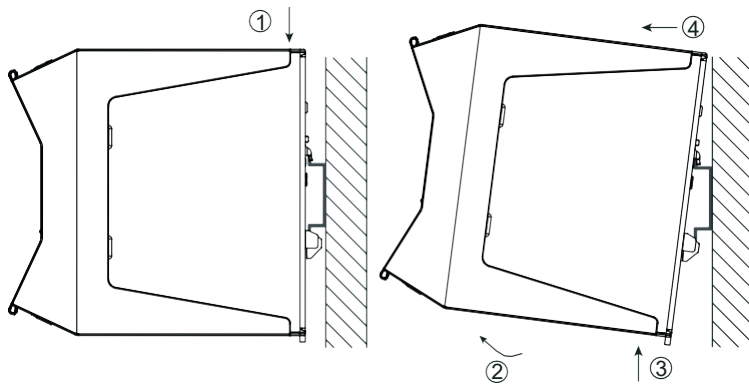

1. Press the unlock button on the top of the device to release the latch from the rail.
2. While pushing the button, slightly tilt the device forward.
3. Pull the device away from the DIN rail by pushing it up.
4. Remove the power supply completely from the rail.

Release Option 2 (by using a screwdriver)

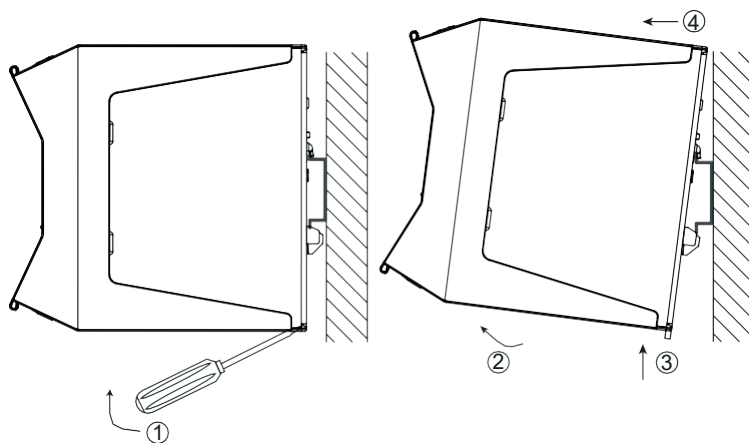

1. Pull the DIN rail latch by using a screwdriver OUT of the device and HOLD it.
2. Tilt the bottom of the device OUT.
3. Pull the device away from the DIN rail by pushing it up.
4. Remove the power supply completely from the rail

Installation Instructions

To guarantee sufficient convection cooling, keep a distance of 20mm above and 40mm below the device. For vertical mounting the device should be installed with the input terminal on the bottom. No space between supplies are required.

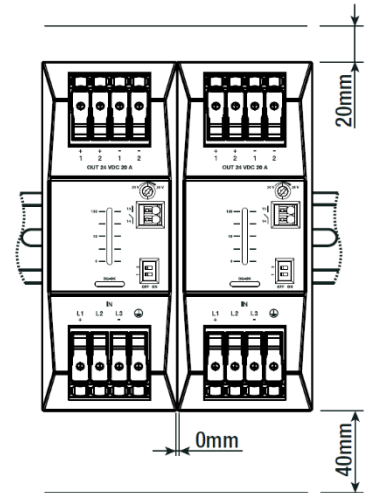

Phase redundancy

- 1) If one phase fails, operation is still guaranteed. (2-phase operation)

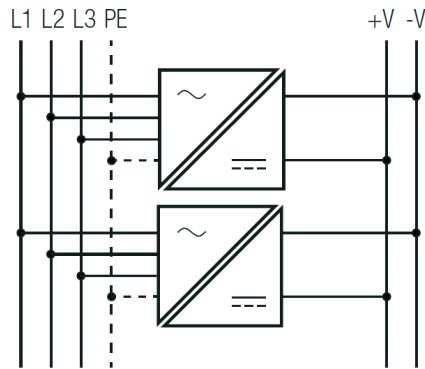

Parallel Operation

- 1) Make sure that the DIP-Switch 1 is "ON" to get into the Parallel Load sharing mode.
- 2) Adjust each power supply to the exact same output voltage with same load and cooling conditions.
- 2) Use the same wire length and cable cross-section for each power supply (star connection) and energize all units at the same time to avoid triggering overload protection.
- 3) Do not use power supplies in parallel in mounting orientations other than the standard mounting orientation (input terminals on the bottom of the unit) or in any other condition where a derating of the output current is required (e.g. above 60°C, ...).
- 4) Pay attention that leakage current, EMI, inrush current, harmonics will increase when using multiple power supplies.

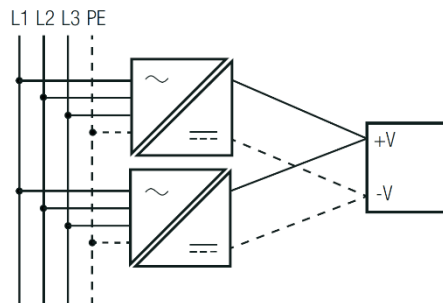

BLOCK DIAGRAM

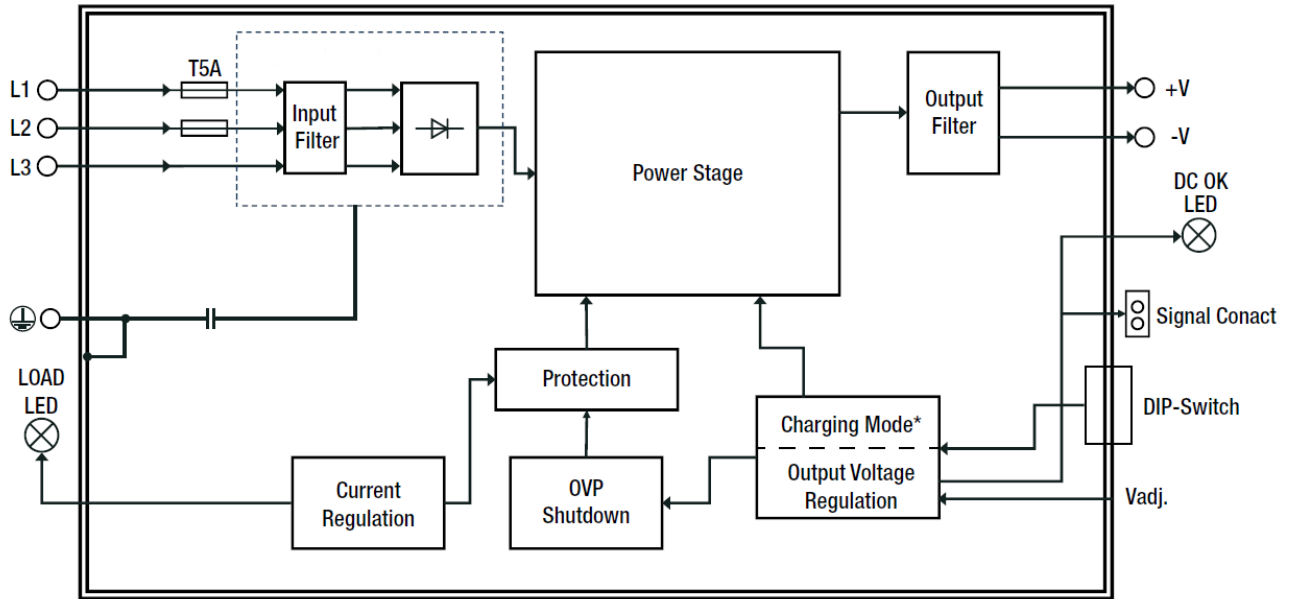

PACKAGING INFORMATION

Parameter	Type	Value
Packaging Dimension (LxWxH)	cardboard box	180 x 175 x 70mm
Packaging Quantity		1 pc
Storage Temperature Range		-40°C to +85°C
Storage Humidity	non-condensing	85% RH max.

The product information and specifications may be subject to changes even without prior written notice. The product has been designed for various applications; its suitability lies in the responsibility of each customer. The products are not authorized for use in safety-critical applications without Premium's explicit written consent. A safety-critical application is an application where a failure may reasonably be expected to endanger or cause loss of life, inflict bodily harm or damage property. The applicant shall indemnify and hold harmless Premium PSU, its affiliated companies and its representatives against any damage claims in connection with the unauthorized use of Premium products in such safety-critical applications