

# DPX-240

## 3AC DIN-Rail Power Supply

### GENERAL FEATURES

- Slim Design (43mm) with 25° Push-In connectors
- Fast tool-less mounting and demounting
- Active Inrush Current Limitation
- 2-phase AC operation 2x350V to 2x575V
- DC-Input Range 430V to 815V/850V 10s
- Highest Efficiency up to 94.1%
- Full Power -40°C/+70°C, Boost Power 150%/5s
- Thermal Power Bonus 120%/45°C
- Highest Lifetime Expectancy 80.000h/40°C
- DC-OK Signal
- Reduced no load power consumption 0.8W to 1.1W



### DESCRIPTION

The slim DPX-240 a high reliability, three phase AC input, 24V/240W DIN rail mount power supply in extremely compact dimensions of 135 x 125mm with a width of only 43mm. It is specially designed for demanding applications in the harsh industrial automation field with an extended mains input surge immunity of up to 6kVAC and return voltage immunity >35V at the output making it suitable for safe operation against back feeding loads like decelerating motors and inductors. These units will deliver up to 240W over the full -40°C to +70°C ambient temperature range with only convection cooling. A Thermal Power Bonus of up to 288W at 45°C plus a power boost of up to 150% for 5s makes them suitable for powering highly inductive or capacitive loads. The unique and innovative modern design with 25° push-in connectors allows easy tool-less installation or replacement. The product is certified according to the global safety standards IEC/EN/UL 62368-1, IEC/EN/UL 61010-1 and IEC/EN/UL/CSA 61010-2-201. Electromagnetic radiated and conducted emissions are compliant to heavy industrial EN 61000-6-4 Class B emission standard and EN 61000-6-2 immunity standard

### SELECTION GUIDE

Part Number	Input Voltage Range [Vdc]	Output Voltage nom. [Vdc]	Output Current max. (1) [A]	Efficiency typ. [%]	Output Power max. (1) [W]	Rated Output Power (2) [W]
DPX-240-35624T	3x 320-575	24	24-28	10	94.1	240

Note1: Efficiency is tested at nominal input (400/480VAC) and full load at +25°C ambient.

Note2: Thermal Power Bonus 120% (T<sub>AMB</sub>= 45°C max.), and Boost Power 150%/7.5sec max.; refer to "Boost Power".

### ACCESSORIES

Part Number	Description
EFC-120-32405	electronic circuit breaker; 4-channel; input voltage DC 24 V adjustable output current 1.75-5.75A and selectable NEC Class 2 mode
EFC-240-32410	electronic circuit breaker; 4-channel; input voltage DC 24 V; adjustable output current 3.5-11.5A
RDM-40-32440	highly efficient n+1 redundancy or decoupling diode module 2 x 20A or 1 x 40A for power supplies with 12V, 24V or 48V output voltage

BASIC CHARACTERISTICS (measured @ T <sub>AMB</sub> = 25°C, 3AC 400VAC full load and after warm-up unless otherwise stated)				
Parameter	Condition	Min.	Typ.	Max.
Nominal Input Voltage	50/60Hz	400VAC		480VAC
Operating Range <sup>(3)</sup>	3 phase operation	320VAC		575VAC
	2 phase operation	350VAC		575VAC
	DC operation refer to „Connections for DC-operation“	continuous	450VDC	815VDC
		10s max.		850VDC
Turn-on Voltage	prevents switching on during 1AC operation	310VAC		
	DC operation	440VDC		
Turn-off Voltage	AC operation	290VAC		
	DC operation	410VDC		
Input Current	AC operation	400VAC		3x 0.7A
		480VAC		3x 0.6A
	DC operation	500VDC		0.8A
Inrush Current	3AC 400VAC, cold start			10A
No Load Power Consumption	3AC 400VAC			0.8W
	3AC 500VAC			1.1W
Input Frequency Range		47Hz		63Hz
Nominal Output Voltage (factory set)			24VDC	
Minimum Load		0%		
Power Factor	full load	0.45		
Start-up time	2 & 3 phase operation, 400VAC		37ms	50ms
Rise time			23ms	30ms
Hold-up time	400VAC		15ms	
	480VAC		30ms	
Internal Operating Frequency			65kHz	
Ripple and Noise	20MHz bandwidth			1% of nom V <sub>OUT</sub>

Note3: The products were submitted for safety files at AC and DC-Input operation. (350V-575VAC and 450-600VDC) If input voltage is >500VDC consider an external fuse according to applicable standards.  
2phase operation is not included in the safety approvals. Additional tests might be necessary when the complete application has to be approved according to UL 62368-1, 61010-1 and UL 61010-2-201.

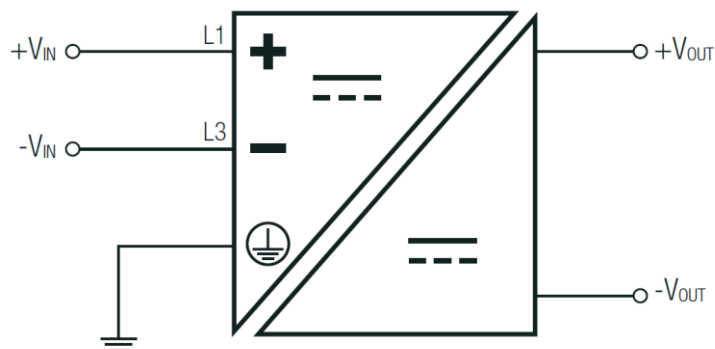
**Connections for DC-operation**



**BASIC CHARACTERISTICS (measured @ T<sub>AMB</sub>= 25°C, 3AC 400VAC full load and after warm-up unless otherwise stated)**

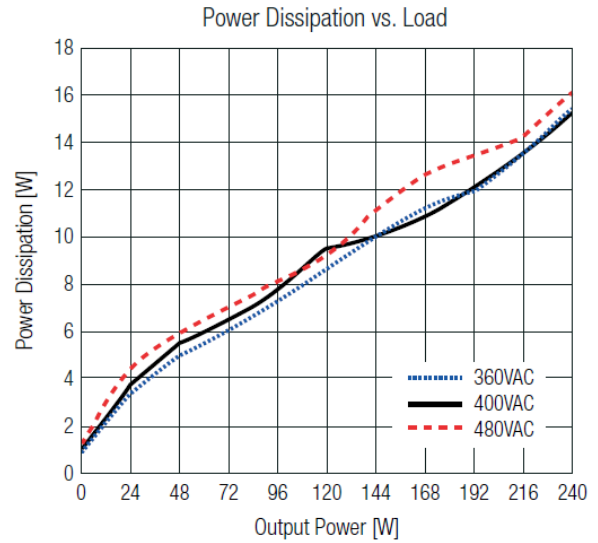
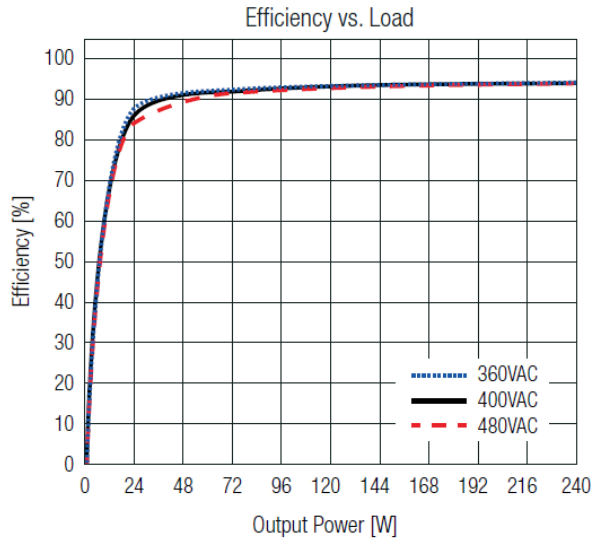

ADDITIONAL FEATURES		
Parameter	Condition	Value
Output Voltage Adjustability <sup>(4)</sup>	on-board potentiometer	24-28VDC
DC-OK LED	LED green	output voltage ok, normal mode
	LED off	abnormal mode, no operation or failure
Signal Contact	closed	normal mode
	open	abnormal mode, no operation or failure
Signal Contact Rating	do not connect signaling contact to hazardous voltages	30VDC/0.1A

Note4: When input voltage is below 350VAC, the output voltage is limited to 24VDC.  
Make sure that the maximum rated output power will not be exceeded when trimming up

REGULATIONS (measured @ T <sub>AMB</sub> = 25°C, 3AC 400VAC full load and after warm-up unless otherwise stated)		
Parameter	Condition	Value
Output Accuracy		±1.0% max.
Line Regulation	low line to high line, full load	±0.1% typ.
Load Regulation	0% to 100% load	±0.4% typ.
Max. Capacitive Load (start-up)		20mF
Transient Response	10-100% load	±3.0% typ.
	recovery time	100ms typ.

PROTECTIONS (measured @ T <sub>AMB</sub> = 25°C, 3AC 400VAC full load and after warm-up unless otherwise stated)		
Parameter	Type	Value
Internal Input Fuse	DC compliant	2x T5A, slow-blow
Easy Fuse Tripping		250%/20ms
External Input Protection		16A C-characteristic circuit breaker
Short Circuit Protection (SCP)		hiccup mode, auto recovery
Over Voltage Protection (OVP)	SELV output	35VDC, latch off
Return Voltage Immunity	continuous	35VDC
	<5 min	38VDC
Absorbing Energy		1.5J
Over Voltage Category (OVC)		OVC II
Over Current Protection (OCP)	<5 sec	>150% of rated load current, hiccup mode, auto recovery
	<20ms <sup>(5)</sup>	>250% of rated load current, hiccup mode, auto recovery
Class of Equipment		Class I with PE connection



PROTECTIONS (measured @ T <sub>AMB</sub> = 25°C, 3AC 400VAC full load and after warm-up unless otherwise stated)			
Parameter	Type		Value
Isolation Voltage (safety certified) <sup>(6)</sup>	tested for 1 minute	I/P to O/P	3.5kVAC / 5kVDC
		I/P to PE	1.6kVAC / 2.5kVDC
		O/P to PE	500VAC / 700VDC
Isolation Resistance	I/P to O/P		4.5MΩ min.
Insulation Grade			reinforced
Earth Leakage Current	480VAC/60Hz		3.5mA max.

Note5: VOUT= 19VDC min.  
 Note6: For repeat Hi-Pot testing, reduce the time and/or the test voltage

ENVIRONMENTAL (measured @ T <sub>AMB</sub> = 25°C, 3AC 400VAC full load and after warm-up unless otherwise stated)			
Parameter	Condition		Value
Operating Ambient Temperature Range	@ natural convection (0.1m/s)	with derating	-40°C to +70°C
		without derating	refer to „Derating Graph“
Operating Altitude <sup>(7)</sup>			5000m
Operating Humidity	non-condensing		95% RH max.
Pollution Degree			PD2
IP Rating			IP20
Shock	according to IEC 60068-2-27 Fa	non-operating	15G/11ms, 3 times (positive/negative) in all axis
Vibration	according to IEC 60068-2-6 Fc	non-operating	5 - 8.4Hz @ 3.5mm deflection 8.4 -150Hz @ 2G, 10 cycles /axis(min-max-min); 1 octave/min
MTBF	according to EN/IEC 61709 (SN29500)		1.015 x 10 <sup>3</sup> hours
Design Lifetime	T <sub>AMB</sub> = 40°C @ 100% Load		80 x 10 <sup>3</sup> hours

Note7: Recognized by safety agency for safe operation up to 5000m. High altitude operation may impact the performance and lifetime

**Derating Graph**  
 (@ Chamber and natural convection 0.1m/s)

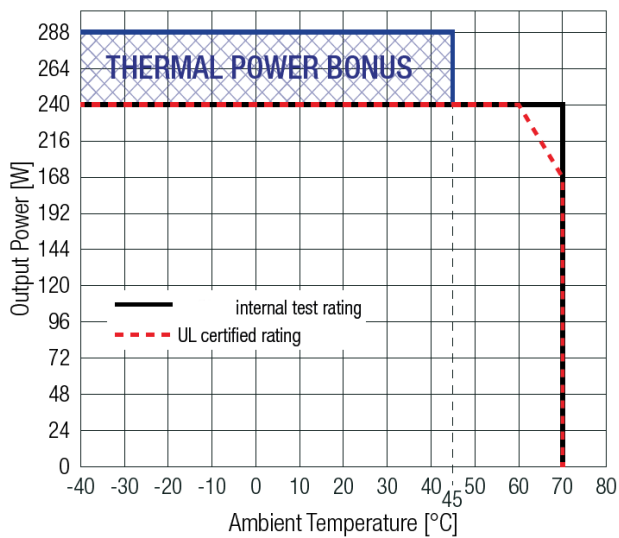

**Boost Power**  
 (400V-480VAC or 500VDC; -40°C to +60°C max.)

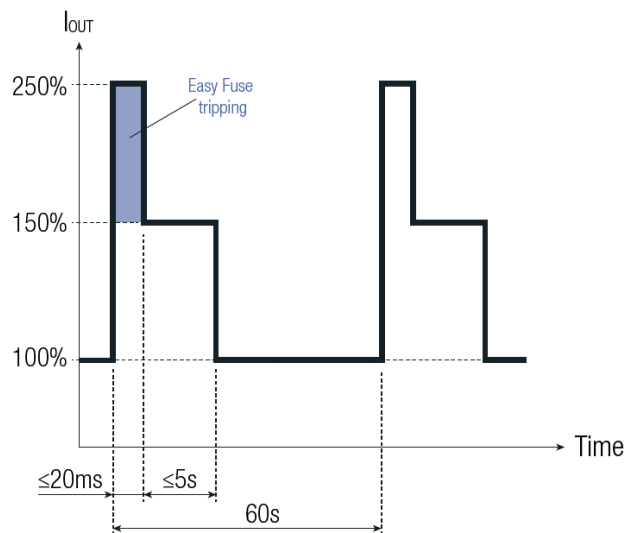



SAFETY & CERTIFICATIONS		
Certificate Type (Safety)	Report Number	Standard
Audio/Video, information and communication technology equipment - Part 1: Safety requirements (CB)		IEC62368-1:2018 3rd Edition
Audio/Video, information and communication technology equipment - Part 1: Safety requirements		EN IEC 62368-1:2020+A11:2020
Audio/Video, information and communication technology equipment - Part 1: Safety requirements		UL62368-1:2019 3rd Edition CAN/CSA-C22.2 No. 62368-1-19 3rd Edition
Electrical Equipment For Measurement, Control, and Laboratory Use; Part 1: General Requirements (CB)		IEC61010-1:2010+A1:2016 3rd Edition
Electrical Equipment For Measurement, Control, and Laboratory Use; Part 1: General Requirements		EN61010-1:2010+A1:2019
Electrical Equipment For Measurement, Control, and Laboratory Use; Part 1: General Requirements		UL61010-1:2012 3rd Edition CAN/CSA-C22.2 No. 61010-1-12 3rd Edition
Electrical Equipment For Measurement, Control, and Laboratory Use; Part 2-201: Particular requirements for control equipment (CB)		IEC61010-2-201:2017 2nd Edition
Electrical Equipment For Measurement, Control, and Laboratory Use; Part 2-201: Particular requirements for control equipment		EN IEC 61010-2-201:2018
Electrical Equipment For Measurement, Control, and Laboratory Use; Part 2-201: Particular requirements for control equipment		UL61010-2-201:2018 2nd Edition CAN/CSA-C22.2 No. 61010-2-201:2018-02-01
RoHS2		RoHS 2011/65/EU + AM2015/863

EMC Compliance according to IEC/EN61000-6-4/6-2	Condition	Standard / Criterion
Electromagnetic compatibility (EMC) - Part 6-2: Generic standards - Immunity standard for industrial environments		IEC/EN61000-6-2:2019
Electromagnetic compatibility (EMC) - Part 6-3: Generic standards - Emission standard for residential area		IEC/EN 61000-6-3:2021
ESD Electrostatic discharge immunity test	Air: ±8kV; Contact: ±6kV	IEC61000-4-2:2008, Criteria A EN61000-4-2:2009, Criteria A
Radiated, radio-frequency, electromagnetic field immunity test	10V/m (80-1000MHz)	IEC/EN61000-4-3:2006+A2:2010, Criteria A
Fast Transient and Burst Immunity	AC Power Port: ±4kV DC-Output Port: ±2kV	IEC/EN61000-4-4:2012, Criteria A
Surge Immunity	AC-Power Port: L1-L2, L1-L3, L2-L3: ±2.5kV L1-PE,L2-PE,L3-PE: ±6kV DC-Output Port: Vout(+) - Vout(-), DC-OK(13-14): ±1kV Vout(+)-PE, Vout(-)-PE: ±2kV	IEC/EN61000-4-5:2014+A1:2017, Criteria A
Immunity to conducted disturbances, induced by radio-frequency fields	10Vrms (0.15-80MHz)	IEC61000-4-6:2013, Criteria A EN61000-4-6:2014, Criteria A
Power Magnetic Field Immunity	30A/m, 50/60Hz	EN61000-4-8:2010, Criteria A
Voltage Dips	400VAC, 50Hz	100%, 5 cycle; 70%, 10 cycles; 40%, 25 cycles; 30%, 25 cycles
Voltage Interruptions	400VAC, 50Hz	100%, 250 cycles
Limits of Harmonic Current Emissions		EN IEC 61000-3-2:2019
Limits of Voltage Fluctuations & Flicker		EN61000-3-3:2013+A1:2017

DIMENSION & PHYSICAL CHARACTERISTICS		
Parameter	Type	Value
Material	chassis	polycarbonate (UL94 V-0) / aluminum
Dimension (HxWxD)		135.0 x 43.0 140.4mm 5.3 x 1.7 x 5.5 inch
Weight		531g 1.17 lbs



DIMENSION & PHYSICAL CHARACTERISTICS

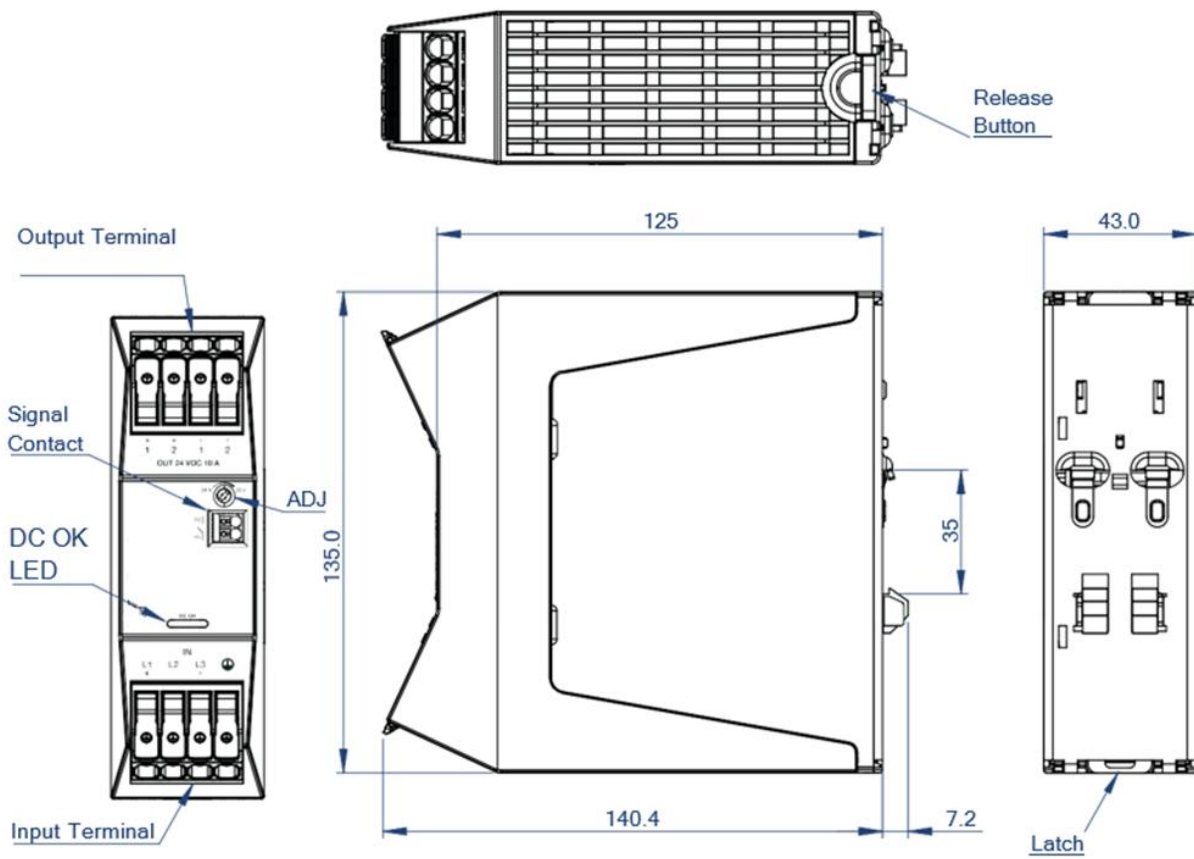

Input & Output Cage Clamp		
Function	AWG	mm <sup>2</sup>
L1, L2, L3	24-8	0.25-6
PE	24-8	0.25-6
+1, +2 (Vout)	24-8	0.25-6
-1, -2 (Vout)	24-8	0.25-6

Wire stripping length: 12-13mm

Push-In Signal Terminal <sup>(9)</sup>		
Function	AWG	mm <sup>2</sup>
Signal (13,14)	24-16	0.25-1.5

Wire stripping length: 8-9mm

Do not connect signaling contact to hazardous voltages

Note8: Use flexible (stranded wire) or solid cables with above wire cross-section is recommended. Use copper conductors designed for an operating temperature of at least 90°C.  
 Note9: Ferrules are required for flexible cable.

Tolerance: ±0.5mm

**Installation Instructions**
**Mounting Instruction**

Mounting Rail: Standard TS35 DIN Rail in accordance with EN 60715.

## Mounting

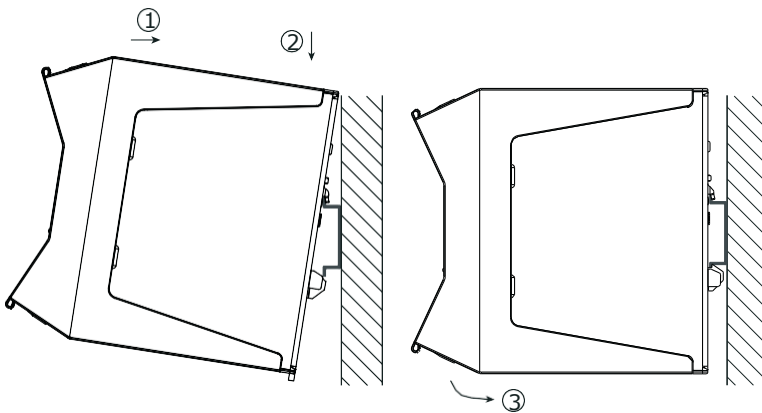

1. Place the device on the DIN rail with a slight upward tilt. Snap the device into the DIN rail.
2. Now tilt the device downwards until it reaches the lower part of the DIN rail.
3. Press the lower part of the device firmly against the rail until the device locks into position on the DIN rail.
4. To make sure it is securely locked in place, give the device a gentle shake.

## Release Option 1 (tool-less)

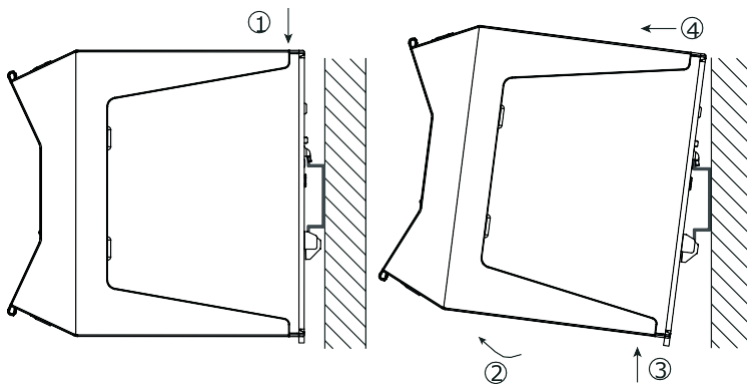

1. Press the unlock button on the top of the device to release the latch from the rail.
2. While pushing the button, slightly tilt the device forward.
3. Pull the device away from the DIN rail by pushing it up.
4. Remove the power supply completely from the rail.

## Release Option 2 (by using a screwdriver)

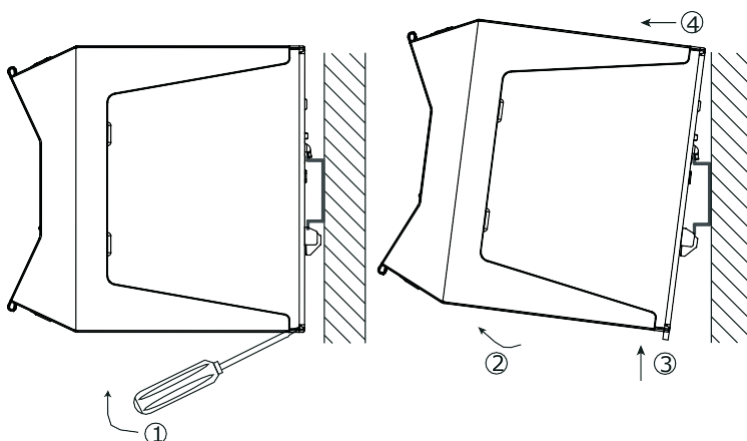

1. Pull the DIN rail latch by using a screwdriver OUT of the device and HOLD it.
2. Tilt the bottom of the device OUT.
3. Pull the device away from the DIN rail by pushing it up.
4. Remove the power supply completely from the rail.



### Installation Instructions

To guarantee sufficient convection cooling, keep a distance of 40mm above and 20mm below the device.

For vertical mounting the device should be installed with the input terminal on the bottom (standard orientation).

For all other mounting orientations, the maximum output power must be reduced by 15% of the nominal power.

No space between supplies is required.

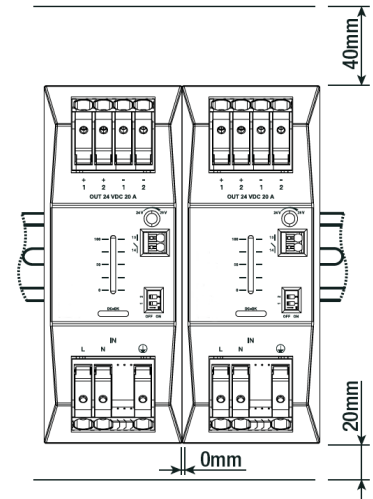

### Phase redundancy

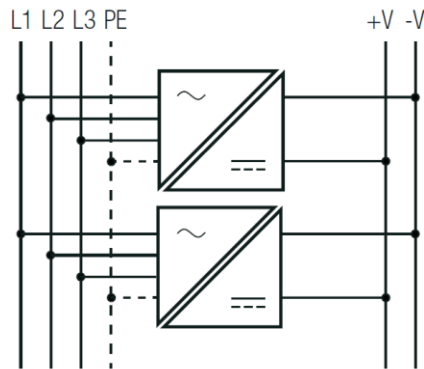

### BLOCK DIAGRAM

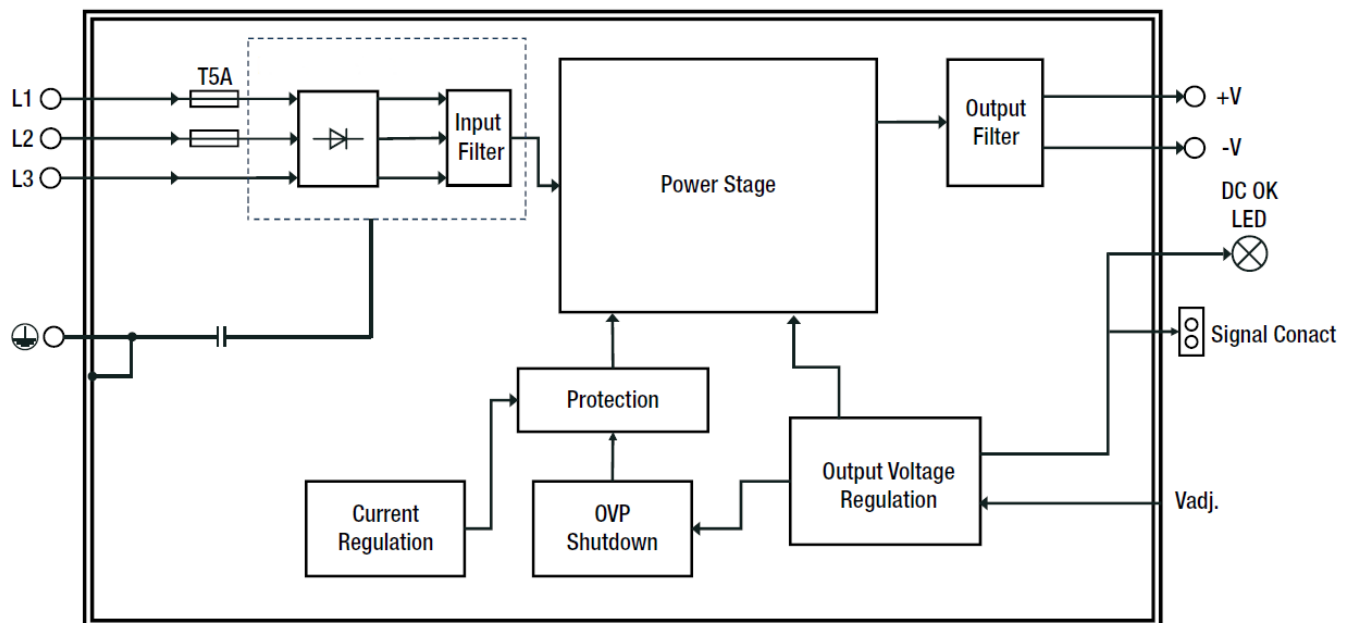



PACKAGING INFORMATION		
Parameter	Type	Value
Packaging Dimension (LxWxH)	cardboard box	175 x 166 x 59mm
Packaging Quantity		1 pc
Storage Temperature Range		-40°C to +85°C
Storage Humidity	non-condensing	85% RH max.

The product information and specifications may be subject to changes even without prior written notice. The product has been designed for various applications; its suitability lies in the responsibility of each customer. The products are not authorized for use in safety-critical applications without Premium's explicit written consent. A safety-critical application is an application where a failure may reasonably be expected to endanger or cause loss of life, inflict bodily harm or damage property. The applicant shall indemnify and hold harmless Premium PSU, its affiliated companies and its representatives against any damage claims in connection with the unauthorized use of Premium products in such safety-critical applications