

DPS-240

1AC DIN-Rail Power Supply

GENERAL FEATURES

- Slim Design (39mm) with 25° Push-In connectors
- Active Power Factor Correction >0.95
- Active Inrush Current Limit
- DC-Input Range 88-370VDC
- No Input Voltage Derating over entire Voltage Range
- Highest Efficiency up to 95%
- Full Power -40°C/+60°C, Boost Power 150%/5s
- Thermal Power Bonus 120%/45°C
- Lifetime Expectancy 273khrs/ 40°C/ 75% load
- Built-in ORing diode
- Reduced no load power consumption typ.1W



DESCRIPTION

The slim DPS-240 is a high reliability, single phase AC input, 240W DIN Rail mount power supply in extremely compact dimensions of 125 x 139mm with a width of only 39mm with 24V output. It is specially designed for demanding applications in the harsh industrial automation field with an extended return voltage immunity up to 50V at the output making it suitable for safe operation against back feeding loads like decelerating motors and inductors. The built-in ORing diode allows parallel and redundant operation without external components. These units will deliver up to 240W over the full -40°C to +60°C ambient temperature range with only convection cooling. An extended power bonus of up to 288W at 45°C plus a power boost of up to 150% for 5s makes them suitable for powering highly inductive or capacitive loads. The unique and innovative modern design with 25° push-in connectors allows easy tool-less installation or replacement. The product is certified according to the global safety standards IEC/EN/UL 61010-1 and IEC/EN/UL/CSA 61010-2-201. Electromagnetic radiated and conducted emissions are compliant to heavy industrial EN 61000-6-3 Class B emission standard and EN 61000-6-2 immunity standard.

SELECTION GUIDE

Part Number	Input Voltage Range [VAC]	Input Voltage Range [VDC]	Output Voltage nom. [VDC]	Adjustable Output Voltage [VDC]	Output Current nom. [A]	Efficiency (1)typ. [%]	rated Output Power (2) [W]
DPS-240-35224	85-277	88-370	24	24-29	10	95	240

Note1: Efficiency is tested at nominal input (230VAC) and full load at +25°C ambient.
 Note2: Thermal Power Bonus 120% (T_{AMB}= 45°C max.), and Boost Power 150%/5sec max.; refer to „Boost Power“

ACCESSORIES

Part Number	Description

EFC-120-32405	electronic circuit breaker; 4-channel; input voltage DC 24 V adjustable output current 1.75-5.75A and selectable NEC Class 2 mode
EFC-240-32410	electronic circuit breaker; 4-channel; input voltage DC 24 V; adjustable output current 3.5-11.5A
RDM-40-32440	highly efficient n+1 redundancy or decoupling diode module 2 x 20A or 1 x 40A for power supplies with 12V, 24V or 48V output voltage



BASIC CHARACTERISTICS (measured @ TAMB= 25°C, 240VAC full load and after warm-up unless otherwise stated)					
Parameter	Condition		Min.	Typ.	Max.
Nominal Input Voltage	50/60Hz		120VAC		240VAC
	DC input		110VDC		240VDC
Operating Range ⁽³⁾	47-63Hz		85VAC		277VAC
	DC operation refer to „Connections for DC-operation“		88VDC		370VDC
Turn-on Voltage	AC operation			70VAC	
	DC operation			85VDC	
Turn-off Voltage	AC operation			60VAC	
	DC operation			65VDC	
Input Current	AC operation	120VAC		2.2A	
		240VAC		1.2A	
	DC operation	110VDC		2.4A	
		240VDC		1.1A	
Inrush Current	cold start	120VAC			2.9A
		240VAC			5.6A
No Load Power Consumption	120/240VAC			1W	2W
Input Frequency Range			47Hz		63Hz
Nominal Output Voltage (factory set)				24VDC	
Minimum Load			0%		
Power Factor	full load	120VAC		0.99	
		240VAC		0.97	
Start-up time	240VAC			700ms	1s
Rise time	240VAC			5ms	
Hold-up time	240VAC			33ms	
Internal Operating Frequency				70kHz	
Ripple and Noise	20MHz bandwidth			100mVp-p	120mVp-p

Note3: The products were submitted for safety files at AC and DC-Input operation. (120-240VAC ±10% and 110-240VDC -15/+20%)

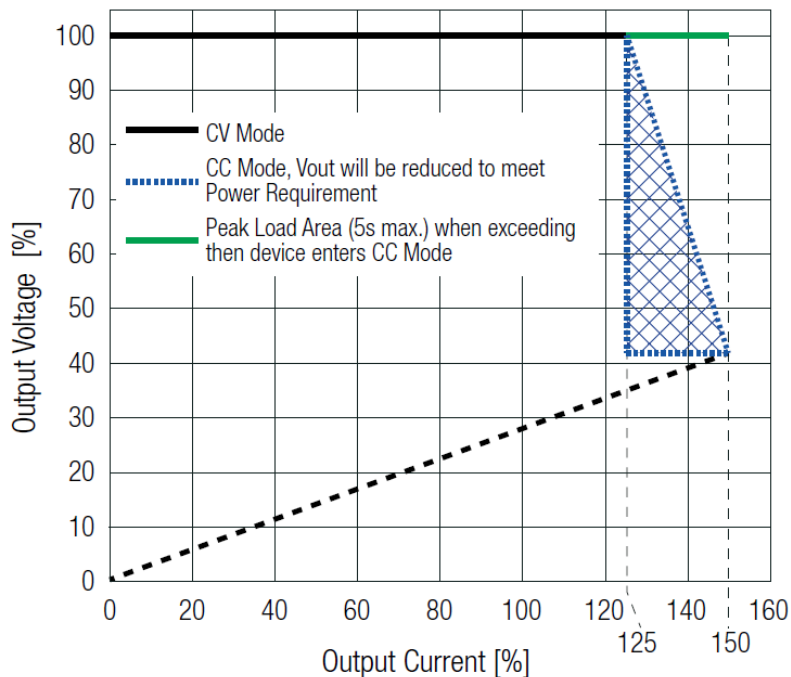

Connections for DC-operation

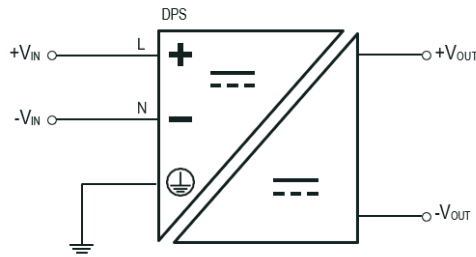

Specifications (measured @ T_{AMB}= 25°C, nom. Vin, full load and after warm-up unless otherwise stated)

DPS-240-35224

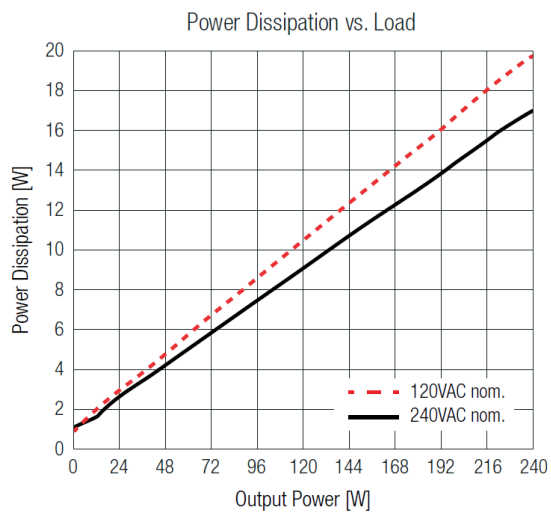
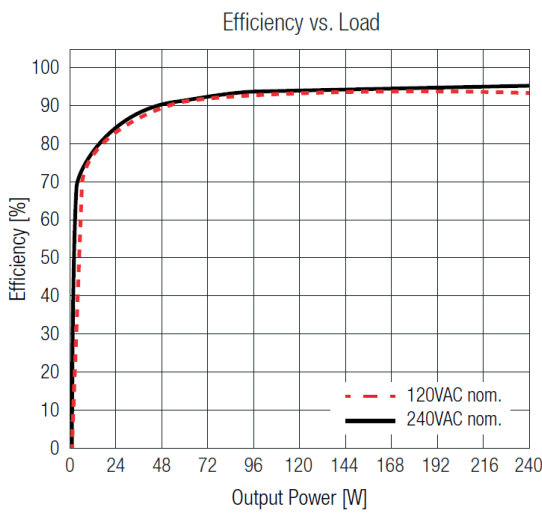

ADDITIONAL FEATURES

Parameter	Condition	Value
Output Voltage Adjustability ⁽⁴⁾	potentiometer	24-29VDC
Boost Power	refer to „Boost Power“	150% for 5s
DC-OK LED	LED green	output voltage ok, normal mode
	LED off	abnormal mode, no operation or failure
Signal Contact	closed	normal mode
	open	abnormal mode, no operation or failure
Signal Contact Rating	do not connect signaling contact to hazardous voltages	30VDC/0.1A

Note4: Make sure that the maximum rated output power will not be exceeded when trimming up.

REGULATIONS (measured @ T_{AMB}= 25°C, 240VAC full load and after warm-up unless otherwise stated)

Parameter	Condition	Value
Output Accuracy		±1.0% max.
Line Regulation	low line to high line, full load	±0.1% max.
Load Regulation	0% to 100% load	±0.5% max.
Max. Capacitive Load (start-up)		80mF
Transient Response	10-100% load	±1.5% typ.
	recovery time	1ms typ.



PROTECTIONS (measured @ T _{AMB} = 25°C, 240VAC full load and after warm-up unless otherwise stated)			
Parameter	Type	Value	
Internal Input Fuse	DC compliant	T6.3A, slow-blow	
Easy Fuse Tripping	refer to „Easy Fuse Tripping“	250%/14ms	
External Input Protection		16A max. C-characteristic circuit breaker or faster	
Short Circuit Protection (SCP)		hiccup mode, auto recovery	
Over Voltage Protection (OVP)	SELV output	33VDC, hiccup mode, auto recovery	
Return Voltage Immunity	continuous	50VDC max.	
Absorbing Energy		1.3J	
Over Voltage Category (OVC)		OVC II (5000m)	
Over Current Protection (OCP)	<5 sec	>150% of rated load current, hiccup mode, auto recovery	
	<14ms ⁽⁵⁾	>250% of rated load current, hiccup mode, auto recovery	
Class of Equipment		Class I with PE connection	
Isolation Voltage (safety certified) ⁽⁶⁾	tested for 1 minute	I/P to O/P	3kVAC / 4kVDC
		I/P to PE	1.6kVAC / 2.5kVDC
		O/P to PE	500VAC / 700VDC
Isolation Resistance	I/P to O/P	4.5MΩ min.	
Insulation Grade		reinforced	
Earth Leakage Current	240VAC/60Hz	1.5mA max.	

Note5: DPS-240-35224 = 20VDC min.

Note6: For repeat Hi-Pot testing, reduce the time and/or the test voltage

Easy Fuse tripping

(120-240VAC or 240VDC; -40°C to +60°C max.)

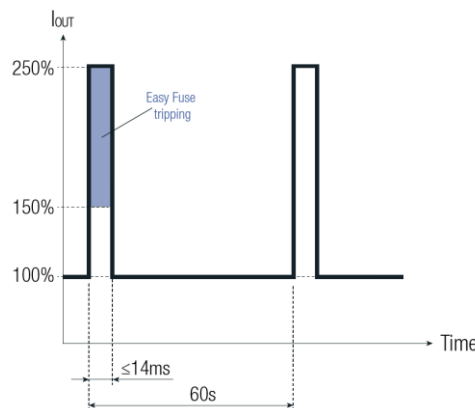

ENVIRONMENTAL (measured @ T _{AMB} = 25°C, 240VAC full load and after warm-up unless otherwise stated)		
Parameter	Condition	Value
Operating Ambient Temperature Range	@ natural convection (0.1m/s)	with derating: -40°C to +70°C
		without derating: refer to „Derating Graph“
Operating Altitude (7)	refer to „Altitude Derating“	5000m
Operating Humidity	non-condensing	95% RH max.
Pollution Degree		PD2
IP Rating		IP20
Shock	according to IEC 60068-2-27 Fa	non-operating: 15G/11ms, 3 times (positive/negative) in all axis
Vibration	according to IEC 60068-2-6 Fc	non-operating: 5 - 8.4Hz @ 3.5mm deflection; 8.4 -150Hz @ 2G, 10 cycles /axis(min-max-min); 1 octave/min
MTBF	according to EN/IEC 61709 (SN29500); TAMB= 40°C	1013 x 103 hours
Lifetime Expectancy	230VAC	refer to table on next page

Note7: Recognized by safety agency for safe operation up to 5000m. High altitude operation may impact the performance and lifetime



ENVIRONMENTAL (measured @ T_{AMB}= 25°C, 240VAC full load and after warm-up unless otherwise stated)

Lifetime Expectancy at 230Vac

DPS-240-35224

Ambient Temperature	50% Load	75% Load	100% Load
+20°C	1255 x 10 ³ hrs.	1092 x 10 ³ hrs.	546 x 10 ³ hrs.
+30°C	627 x 10 ³ hrs.	546 x 10 ³ hrs.	273 x 10 ³ hrs.
+40°C	314 x 10 ³ hrs.	273 x 10 ³ hrs.	137 x 10 ³ hrs.

Note8: The stated lifetime expectancy of more than 15 years is provided for comparison purposes only and does not imply continuous 24/7 operation.

Derating Graph

(@ Chamber and natural convection 0.1m/s, standard mounting orientation)

Derating Graph

(@ Chamber and natural convection 0.1m/s, standard mounting orientation)

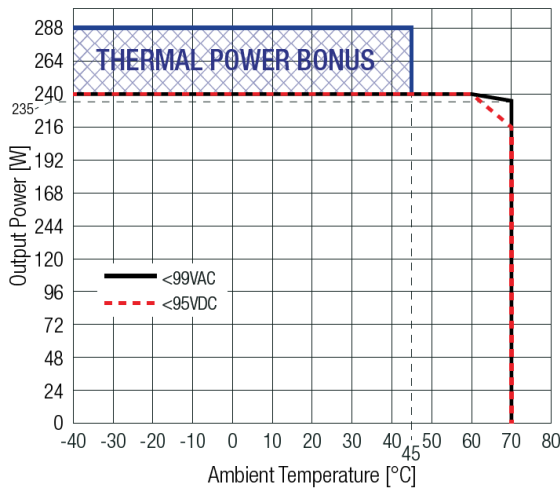

Boost Power

(-40°C to +60°C max.)

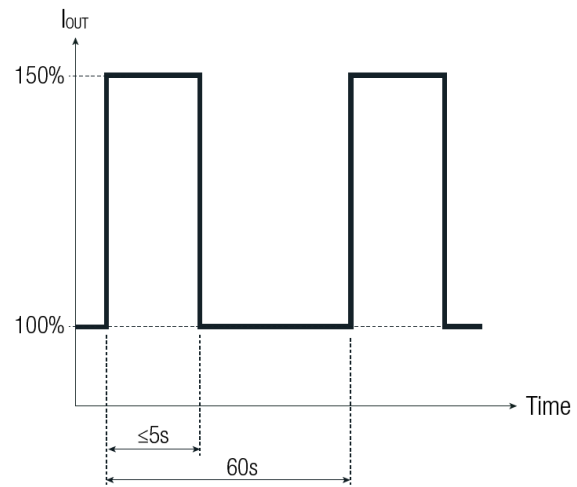

Note9: Thermal power bonus only applies at an input voltage ≥90VAC and ≥106VDC

Altitude Derating

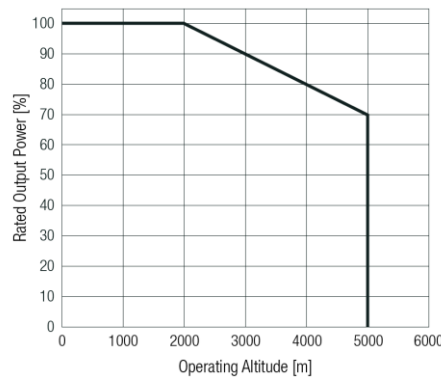

SAFETY & CERTIFICATIONS

Certificate Type (Safety)	Report Number	Standard
Electrical Equipment For Measurement, Control, and Laboratory Use; Part 1: General Requirements (CB)		IEC61010-1:2010+A1:2016 3rd Edition
Electrical Equipment For Measurement, Control, and Laboratory Use; Part 1: General Requirements		EN61010-1:2010+A1:2019
Electrical Equipment For Measurement, Control, and Laboratory Use; Part 1: General Requirements		UL61010-1:2012 3rd Edition CAN/CSA-C22.2 No. 61010-1-12 3rd Edition
Electrical Equipment For Measurement, Control, and Laboratory Use; Part 2-201: Particular requirements for control equipment (CB)		C61010-2-201:2017 2nd Edition EN IEC 61010-2-201:2018
Electrical Equipment For Measurement, Control, and Laboratory Use; Part 2-201: Particular requirements for control equipment		UL61010-2-201:2018 2nd Edition CAN/CSA-C22.2 No. 61010-2-201:2018-02-01
RoHS2		RoHS 2011/65/EU + AM2015/863

EMC Compliance	Condition	Standard / Criterion
Electromagnetic compatibility (EMC) - Part 6-2: Generic standards - Immunity standard for industrial environments		IEC/EN61000-6-2:2019
Electromagnetic compatibility (EMC) - Part 6-3: Generic standards - Emission standard for residential area		IEC/EN 61000-6-3:2021
ESD Electrostatic discharge immunity test	Air: ±8kV; Contact: ±6kV	IEC61000-4-2:2008, Criteria A EN61000-4-2:2009, Criteria A
Radiated, radio-frequency, electromagnetic field immunity test	10V/m (80-1000MHz)	IEC/EN61000-4-3:2006+A2:2010, Criteria A
Fast Transient and Burst Immunity	AC Power Port: ±4kV DC-Output Port: ±2kV	IEC/EN61000-4-4:2012, Criteria A
Surge Immunity	AC-Power Port: L-N: ±2kV L-PE, N-PE,: ±4kV	IEC/EN61000-4-5:2014+A1:2017, Criteria A
	DC-Output Port: Vout(+)- Vout(-): ±1kV Vout(+)-PE, Vout(-)-PE: ±1kV	
Immunity to conducted disturbances, induced by radio-frequency fields	10Vrms (0.15-80MHz)	IEC61000-4-6:2013, Criteria A EN61000-4-6:2014, Criteria A
Power Magnetic Field Immunity	30A/m, 50/60Hz	EN61000-4-8:2010, Criteria A
Voltage Dips	230VAC, 50Hz 100%, 5 cycle; 70%, 10 cycles; 40%, 25 cycles; 30%, 25 cycles	IEC61000-4-11:2004+A1:2017, Criteria B
Voltage Interruptions	230VAC, 50Hz 100%, 250 cycles	IEC61000-4-11:2004+A1:2017, Criteria B
Limits of Harmonic Current Emissions		EN IEC 61000-3-2:2019
Limits of Voltage Fluctuations & Flicker		EN61000-3-3:2013+A1:2017

BLOCK DIAGRAM

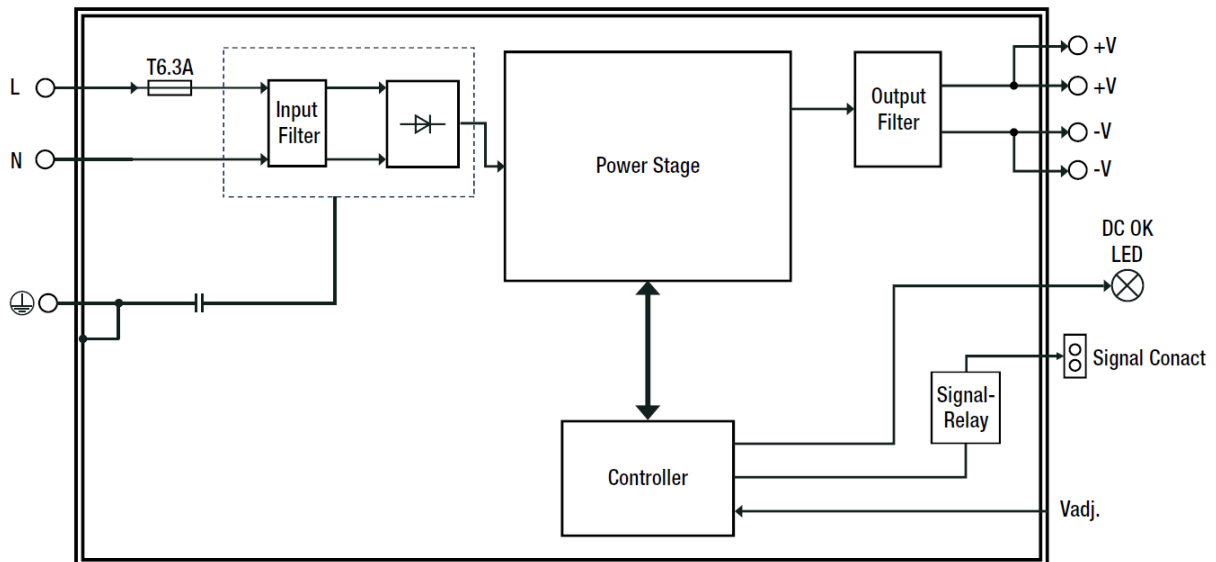



DIMENSION & PHYSICAL CHARACTERISTICS		
Parameter	Type	Value
Material	chassis	polycarbonate (UL94 V-0) / aluminum
Dimension (HxWxD)		125.0 x 39.0 x 139.0mm 4.9 x 1.5 x 4.47 inch
Weight		600g 1.32 lbs

Dimension Drawing (mm)

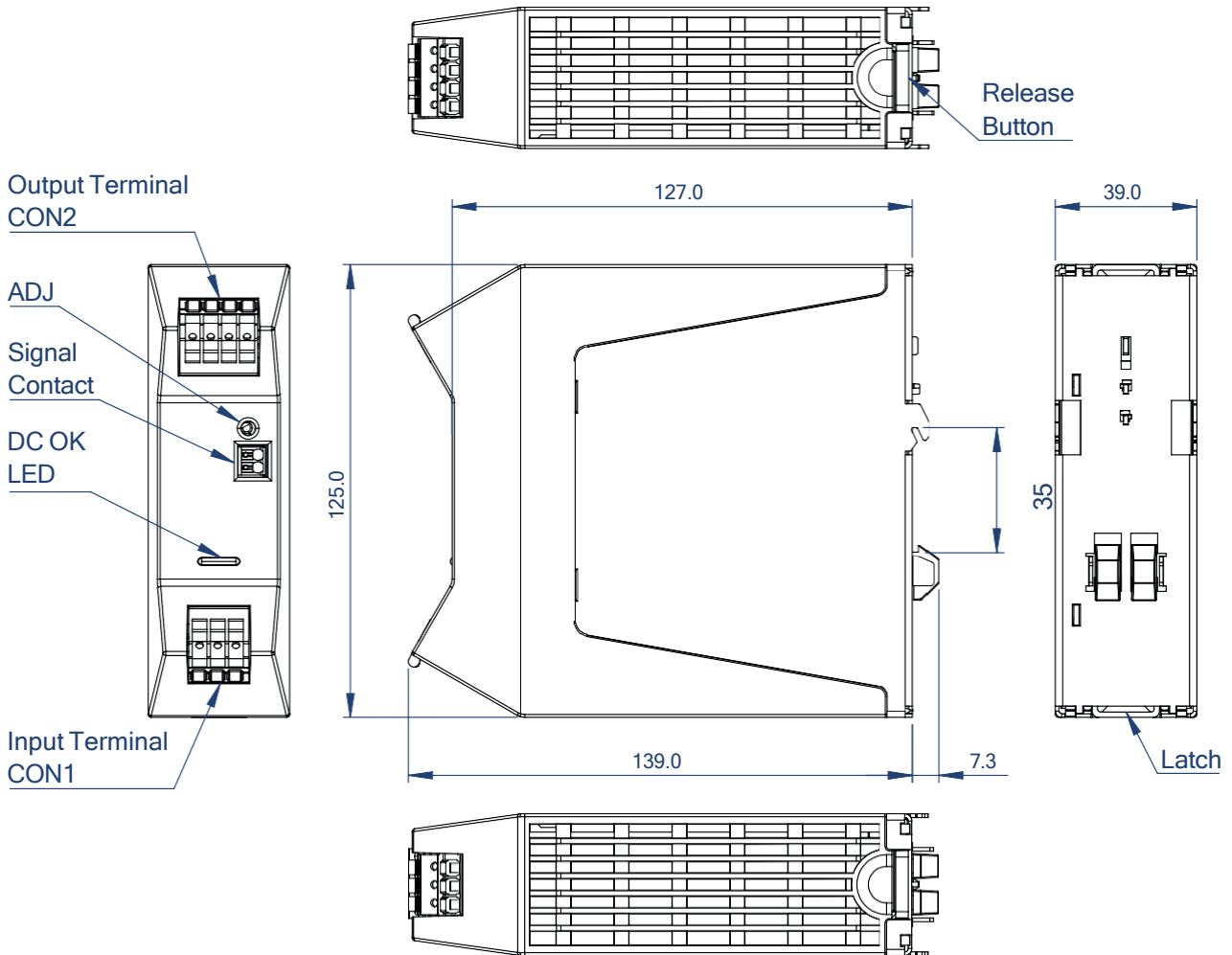
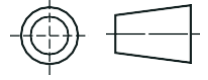

Input & Output Cage Clamp

Function	AWG	mm ²
L, N	24-12	0.25-4
PE	24-12	0.25-4
+1, +2 (Vout)	24-12	0.25-4
-1, -2 (Vout)	24-12	0.25-4

Wire stripping length: 10-12mm

Push-In Signal Terminal ⁽¹¹⁾

Function	AWG	mm ²
Signal (13,14)	24-16	0.25-1.5

Wire stripping length: 8-9mm

Note11: Do not connect signaling contact to hazardous voltages. Ferrules are required for flexible cable.

Note8: Use flexible (stranded wire) or solid cables with above wire cross-section is recommended. Use copper conductors designed for an operating temperature of at least 90°C.

Tolerance: ±0.5mm

Mounting Instruction

Mounting Rail: Standard TS35 DIN Rail in accordance with EN 60715.

Mounting

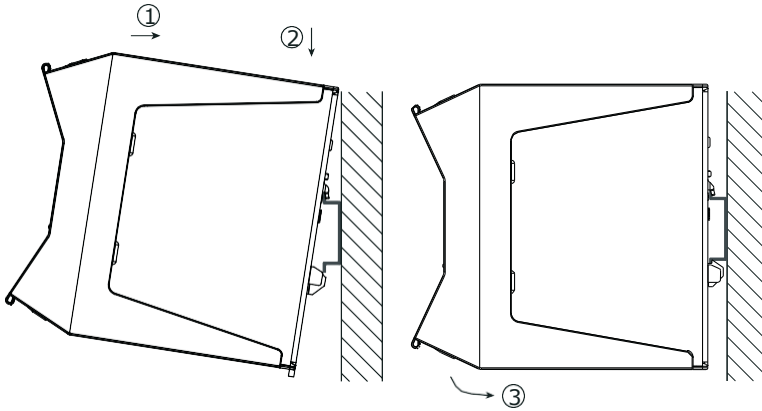

1. Place the device on the DIN rail with a slight upward tilt. Snap the device into the DIN rail.
2. Now tilt the device downwards until it reaches the lower part of the DIN rail.
3. Press the lower part of the device firmly against the rail until the device locks into position on the DIN rail.
4. To make sure it is securely locked in place, give the device a gentle shake.

Release Option 1 (tool-less)

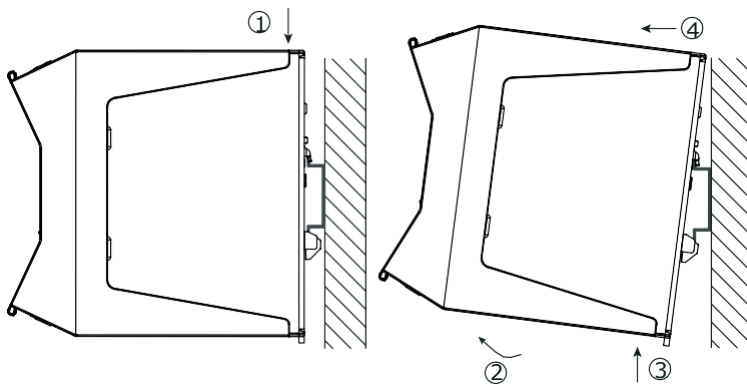

1. Press the unlock button on the top of the device to release the latch from the rail.
2. While pushing the button, slightly tilt the device forward.
3. Pull the device away from the DIN rail by pushing it up.
4. Remove the power supply completely from the rail.

Release Option 2 (by using a screwdriver)

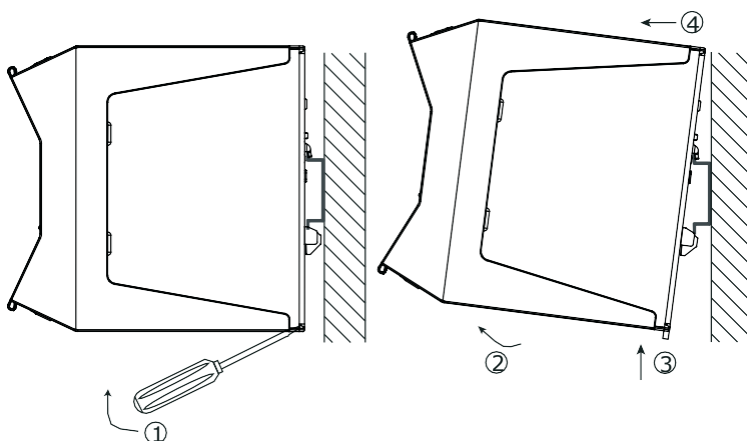

1. Pull the DIN rail latch by using a screwdriver OUT of the device and HOLD it.
2. Tilt the bottom of the device OUT.
3. Pull the device away from the DIN rail by pushing it up.
4. Remove the power supply completely from the rail

Installation Instructions

To guarantee sufficient convection cooling, keep a distance of 40mm above and 20mm below the device.

For vertical mounting the device should be installed with the input terminal on the bottom (standard orientation).

For all other mounting orientations, the maximum output power must be reduced by 15% of the nominal power.

No space between supplies is required.

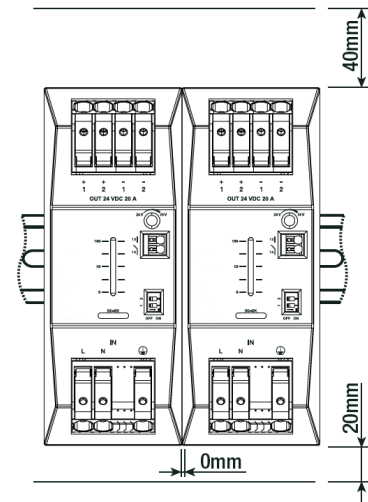

Parallel operation for redundancy 1+1

1. Adjust each power supply to the exact same output voltage with same load and cooling conditions.
2. Use the same wire length and cable cross-section for each power supply (star connection) and energize all units at the same time to avoid triggering overload protection.
3. It must be ensured that one of the power supply is able to provide the total required output power of the DC load to be supplied.
4. In normal operation, each of the two power supplies will be utilized by up to 50%.
5. ATTENTION: Leakage current, EMI, inrush current, harmonics will increase when using multiple power supplies.

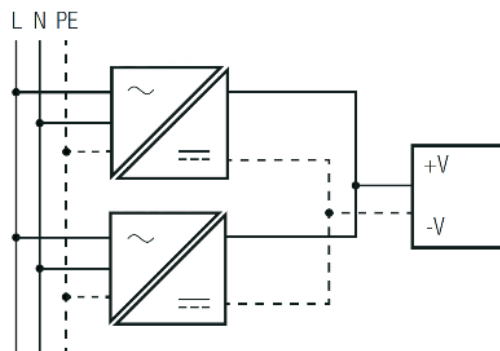

6.

Parallel operation for increasing output power 1+n

1. Adjust each power supply to the exact same output voltage with same load and cooling conditions.
2. Use the same wire length and cable cross-section for each power supply (star connection) and energize all units at the same time to avoid triggering overload protection.
3. A 10% safety margin may be recommended because the power distribution may be slightly asymmetrical depending on the cabling.
4. ATTENTION: Leakage current, EMI, inrush current, harmonics will increase when using multiple power supplies.

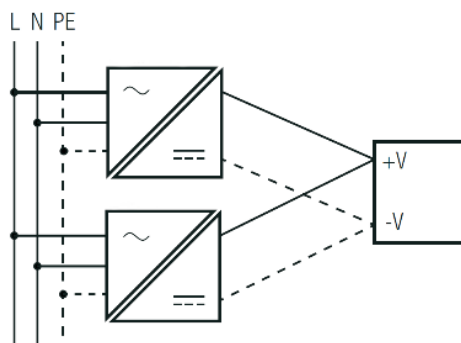

Series Operation

1. Only use PSU with the same type and performance class with identical parameters.
2. To increase the DC output voltage, connect 2 or more power supply units in series.
3. Therefore, negative output terminal "-1" of the first power supply unit must be connected to the positive output terminal "+1" of the second power supply unit and routed to the load. Depending on the common output-side earth reference point of the power supply unit, see below table/figures as example.
4. ATTENTION: Leakage current, EMI, inrush current, harmonics will increase when using multiple power supplies.

Example with 2 PSU's in series:	Figure 1	Figure 2	Figure 3
DPS-240-35224	+48Vdc	-48Vdc	±24Vdc

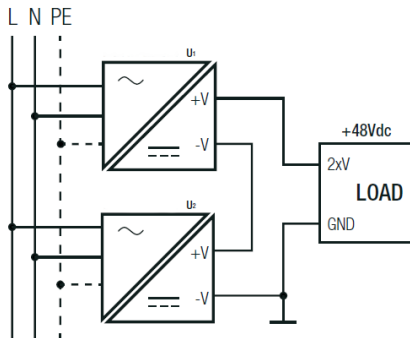

Figure 1

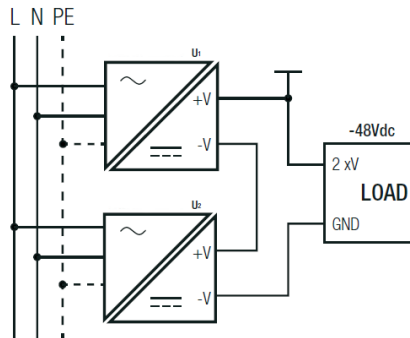

Figure 2

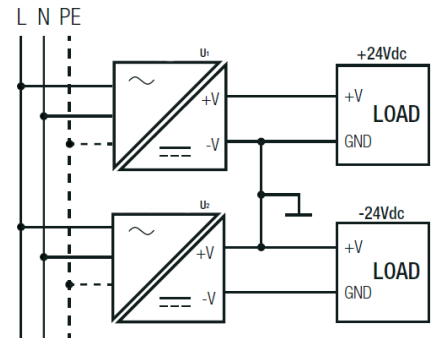

Figure 3

PACKAGING INFORMATION		
Parameter	Type	Value
Packaging Dimension (LxWxH)	cardboard box	137.0 x 153.0 x 63.0mm
Packaging Quantity		1 pc
Storage Temperature Range		-40°C to +85°C
Storage Humidity	non-condensing	85% RH max.

The product information and specifications may be subject to changes even without prior written notice. The product has been designed for various applications; its suitability lies in the responsibility of each customer. The products are not authorized for use in safety-critical applications without Premium's explicit written consent. A safety-critical application is an application where a failure may reasonably be expected to endanger or cause loss of life, inflict bodily harm or damage property. The applicant shall indemnify and hold harmless Premium PSU, its affiliated companies and its representatives against any damage claims in connection with the unauthorized use of Premium products in such safety-critical applications